



# DATA CENTERS

---

SUMMER EDITION

CONSULTING - SPECIFYING  
**engineer**<sup>®</sup>  
eBOOK



**G&W** Electric  
Engineered to order. Built to last.

**S P X**<sup>®</sup>  
COOLING TECHNOLOGIES

# Contents

---

- 3** — How to design standby power systems to withstand storms
- 16** — Fiberglass Conduit VS PVC Conduit
- 17** — Edwardsport IGCC Power Plant
- 19** — How to design data center electrical and power systems
- 26** — Data Center Process Cooling
- 27** — Cooling Towers Offer Water and Energy Savings as Part of Efficient Data Center Cooling Systems
- 36** — Picking software to model electrical systems
- 46** — ALWAYS On | ALWAYS Reliable | ALWAYS Mission Critical
- 49** — Know when, how to specify a rooftop unit





# How to design standby power systems to withstand storms

*Facility owners and design professionals must consider protection from severe weather events when designing standby power systems*

**H**urricanes and other severe weather events pose a substantial risk to maintaining mission critical facility operations. Loss of power for critical water treatment and wastewater processing infrastructure can result in loss of both production and revenue and can threaten public safety and the environment. A reliable standby power system incorporating severe weather protection provisions will mitigate these risks and help maintain facility operations and continuity of service.

Standby generators are not designed to be exposed to the elements, so they are typically protected by either a manufactured outdoor enclosure or a dedicated generator room in a building.

An outdoor enclosure can either be a skin-over enclosure (slightly larger than the generator) with access panels to maintain the generator or a walk-in type enclosure allowing staff to enter the enclosure for maintenance. Outdoor enclosures offer minimal customization for storm protection.

Designers should avoid using the terms “stormproof” or “weatherproof” construction when specifying generator enclosures. The proper terms are “storm resistant” or “weather resistant.” Regardless of how well-maintained the generator is, there is still a potential need to service generators during severe weather. An outdoor enclosure may subject maintenance staff to adverse weather conditions as staff may need to work

How to design standby power systems to withstand storms

Fiberglass Conduit VS PVC Conduit

Edwardsport IGCC Power Plant

How to design data center electrical and power systems

Data Center Process Cooling

Cooling Towers Offer Water and Energy Savings as Part of Efficient Data Center Cooling Systems

Picking software to model electrical systems

ALWAYS On | ALWAYS Reliable | ALWAYS Mission Critical

Know when, how to specify a rooftop unit

## How to design standby power systems to withstand storms

outdoors or inside the small metal enclosure.

If an outdoor enclosure is used, the design team should consider and clearly define in the project manual the following to minimize potential damage:

- Structural engineer to determine the required wind pressures that the enclosure must resist.
- Mechanical engineer to determine the required air inlet and outlets to mitigate water penetration into the enclosure.
- Where custom hoods and/or Air Movement and Control Association International Inc. certified louvers are not available, screen walls should be considered to provide added protection.



*Figure 2: This shows a generator located in a building facing the exhaust side of the space. This image highlights the advantages of a fully customizable space and space for maintenance. Courtesy: CDM Smith*

Advantages of an outdoor enclosure include smaller site footprint and lower design and construction costs. Disadvantages include limited ability to customize and limited space for maintenance, especially during severe weather.

### How to design standby power systems to withstand storms

Fiberglass Conduit VS PVC Conduit

Edwardsport IGCC Power Plant

How to design data center electrical and power systems

Data Center Process Cooling

Cooling Towers Offer Water and Energy Savings as Part of Efficient Data Center Cooling Systems

Picking software to model electrical systems

ALWAYS On | ALWAYS Reliable | ALWAYS Mission Critical

Know when, how to specify a rooftop unit

Buildings housing generator rooms are typically pre-engineered metal buildings, made of reinforced concrete frame with masonry infill or reinforced masonry. However, it is also important for the building construction to resist damage from windborne debris. Reinforced masonry construction is a typical method for constructing generator rooms to protect the facility during severe weather. Generator rooms offer more flexibility and customization to accommodate client preferences and aesthetics.

Regardless of how well-maintained the generator is, there is still a potential need to service generators during severe weather. Generator rooms in buildings provide shelter and protection for maintenance personnel, enabling them to work on equipment without being subjected to adverse weather conditions. Disadvantages include increased design and construction costs.

In coastal areas or areas prone to flooding, facility construction should include mitigation methods for rising water. For mission critical facilities, generators should be located above the 100-year flood level or other local design condition. This may require placing outdoor enclosures on an elevated platform or providing an elevated building structure. Flood barriers could be considered for noncritical facilities.

### **Cooling systems**

Generators produce a significant amount of heat when operating. For the generator to function properly, this heat must be removed to maintain the engine block temperature and ambient space temperature within the operational range of the generator.

Heat within the engine is removed by circulating coolant through the engine block. The closed-loop coolant system is typically air-cooled and consists of a radiator, piping

### **How to design standby power systems to withstand storms**

Fiberglass Conduit VS PVC Conduit

Edwardsport IGCC Power Plant

How to design data center electrical and power systems

Data Center Process Cooling

Cooling Towers Offer Water and Energy Savings as Part of Efficient Data Center Cooling Systems

Picking software to model electrical systems

ALWAYS On | ALWAYS Reliable | ALWAYS Mission Critical

Know when, how to specify a rooftop unit



and pumps. Radiators can either be skid- or remote-mounted outdoors. Skid-mounted radiator fans are the simplest and most reliable form of generator cooling because radiator fans are connected right to the crankshaft of the engine. All components are located within the generator enclosure or room, which minimizes potential downtime during severe weather. Skid-mounted fans are sized by the generator manufacturer to provide cooling air for the radiator core and to remove heat dissipated by the engine.

Remote-mounted radiators consist of a radiator core and a cooling fan. If the skid-mounted pumps are not capable of circulating the liquid through the radiator cooling loop, a separate heat exchanger and auxiliary pumping system will be required. When remote-mounted radiators are used, separate exhaust fans are required to dissipate heat radiated off the surface of the generator. These fans are nearly as large (50% to 75%) as a skid-mounted radiator fan.

Remote-mounted radiators are less reliable because of the additional complexity and equipment noted above. If remote radiators are used, the design team should consider the following to minimize potential damage:

- Secure the remote-mounted radiator, piping systems and exterior exhaust fans to meet wind loads.
- Provide screen walls to protect remote radiators from windborne debris.
- Use exhaust fans located inside the generator room instead of outside on the roof or walls, protecting them from potential damage from windborne debris.

### How to design standby power systems to withstand storms

Fiberglass Conduit VS PVC Conduit

Edwardsport IGCC Power Plant

How to design data center electrical and power systems

Data Center Process Cooling

Cooling Towers Offer Water and Energy Savings as Part of Efficient Data Center Cooling Systems

Picking software to model electrical systems

ALWAYS On | ALWAYS Reliable | ALWAYS Mission Critical

Know when, how to specify a rooftop unit

### Air inlets and outlets

Air inlets and outlets required for generator cooling and combustion airflows are the most critical aspect of protecting a standby power system. Table 1 summarizes the required airflows from two generator manufacturers, as well as the gross inlet and outlet free area opening sizes for a large 2,250-kilowatt generator. Free area is the total minimum area of the opening in the supply outlet or return inlet through which air can pass. Free area is derived by taking the total open area of a louver (after subtracting all obstructions such as blades and frame) and dividing by the overall wall opening.

The gross free area required for the air intake is roughly 150 square feet and the gross free area required for the air exhaust is roughly 100 square feet. Depending on the type of air inlet/outlet used, the net free area (or actual opening size) required can be up to four times the gross free area. Protecting these openings from the effects of wind, rain and windborne debris is imperative to maintain generator operation during severe weather.



Figure 3: Shown is a generator located in outdoor enclosure with sub-base fuel tank. This image highlights the small site footprint of an outdoor enclosure and the limited amount of space around and within the enclosure for maintenance.

Courtesy: CDM Smith

### How to design standby power systems to withstand storms

Fiberglass Conduit VS PVC Conduit

Edwardsport IGCC Power Plant

How to design data center electrical and power systems

Data Center Process Cooling

Cooling Towers Offer Water and Energy Savings as Part of Efficient Data Center Cooling Systems

Picking software to model electrical systems

ALWAYS On | ALWAYS Reliable | ALWAYS Mission Critical

Know when, how to specify a rooftop unit

Manufacturer	Radiator airflow	Combustion airflow	Total airflow	Gross inlet free area at 750 fpm	Gross outlet free area at 1,000 fpm
A	98,900 cfm	7,215 cfm	106,115 cfm	142 square feet	99 square feet
B	106,000 cfm	8,665 cfm	114,665 cfm	153 square feet	106 square feet

**Louvers**—Louvers are the most common form of air inlets/outlets used for generators. There are several test protocols for evaluating louver performance in simulated severe weather events. AMCA 500-L, 511 and 550 include testing protocols and ratings for the beginning point of water penetration and wind-driven rain resistance. The beginning point of water penetration test simulates a nonwind-driven (vertical) rainfall and uses a fan drawing air through the louver to determine the intake air velocity through the louver opening at which 0.01 oz. water penetration per square foot of louver free area begins to penetrate the louver. The wind-driven rain resistance test simulates a wind-driven (horizontal) rainfall and uses a fan and water nozzles to push simulated rainfall through the louver to determine the amount of water penetration. AMCA 540 includes testing protocols and ratings for impact resistance of louvers. The impact resistance test involves launching 2×4-foot timber projectiles at the louver sample from specific locations and at specific velocities to determine if the louver can resist penetration of windborne debris.

The amount of water penetration from a nonwind-driven rainfall is typically a mist of water that could collect on electronic components of the generator and cause generator failure. The amount of water penetration from a wind-driven rainfall can range from a similar mist of water through a wind-driven rain-resistant louver, to significant amounts of water penetration through nonwind-driven rain-resistant louvers that could

*Table 1: This summarizes the required airflows from two generator manufacturers in cubic feet per minute, as well as the gross inlet and outlet free area opening sizes for a large 2,250-kilowatt generator.*

*Courtesy: CDM Smith*

## How to design standby power systems to withstand storms

Fiberglass Conduit VS PVC Conduit

Edwardsport IGCC Power Plant

How to design data center electrical and power systems

Data Center Process Cooling

Cooling Towers Offer Water and Energy Savings as Part of Efficient Data Center Cooling Systems

Picking software to model electrical systems

ALWAYS On | ALWAYS Reliable | ALWAYS Mission Critical

Know when, how to specify a rooftop unit



be drawn through the generator and cause generator failure.

Acoustic louvers, drainable blade louvers and wind-driven rain louvers are the most common types of louvers used for generators. Acoustical louvers are commonly used for generator applications to provide sound attenuation. Acoustical louvers provide roughly 20% to 30% free area, so using our sample generator gross free area of 150 square feet of intake area, the total net free area required is 500 to 750 square feet.

Acoustical louvers have a beginning point of water penetration ranging from roughly 800 to 1,000 feet per minute. Drainable blade louvers are designed to mitigate non-wind-driven water penetration. This type of louver provides roughly 50% to 60% free area with a beginning point of water penetration ranging from roughly 1,000 to 1,250 fpm. There are some models available for both acoustical and drainable blade that are impact rated, but neither is effective at mitigating wind-driven water penetration. Wind-driven rain-resistant louvers are designed to mitigate wind-driven rain, provide roughly 40% to 50% free area and have a beginning point of water penetration of 1,250 fpm or higher. Impact-rated models are available.



Figure 4: The exterior of an electrical and generator building with intake and exhaust plenums is shown.  
Courtesy: CDM Smith

### How to design standby power systems to withstand storms

Fiberglass Conduit VS PVC Conduit

Edwardsport IGCC Power Plant

How to design data center electrical and power systems

Data Center Process Cooling

Cooling Towers Offer Water and Energy Savings as Part of Efficient Data Center Cooling Systems

Picking software to model electrical systems

ALWAYS On | ALWAYS Reliable | ALWAYS Mission Critical

Know when, how to specify a rooftop unit

While louvers have varying ability to mitigate water penetration, they provide no protection from the impacts of positive/negative pressurization related to direct wind. For instance, the radiator fan may not be able to overcome the positive pressure of high winds directly flowing at the louver. This could cause the generator to overheat. Additionally, high-performance louvers are typically limited to smaller sizes than other louvers. If multi-section louvers must be provided, additional support framing will be required.

**Wall hoods and roof hoods**—The main advantage of hoods is that they provide nearly 100% free area. Wall hoods are typically custom fabrications, while roof hoods are typically premanufactured by fan manufacturers. Wall hoods can be used for both intake and exhaust applications and provide some impact resistance for the wall openings depending on the construction of the hood. Wall hood supports must be designed for code required wind loads. Roof hoods are mostly used for intake applications.

Exhaust applications require significant ductwork to connect the radiator fan to the roof hood. Radiator fans have limited external static pressure to accommodate ductwork. Most larger hoods will require additional tie-down supports. For the example generator air flows, using roof hoods would still require +/-150 square feet of roof opening area.

There are no testing protocols for hoods. Both wall and roof hoods can be effective at mitigating nonwind-driven water penetration, but are ineffective at mitigating wind-driven water penetration based on empirical data. Penthouse type roof hoods using AMCA wind-driven rain louvers are effective at mitigating wind-driven rain; however, the addition of the louvers reduces the free area and increases the pressure drop across the intake.

### How to design standby power systems to withstand storms

Fiberglass Conduit VS PVC Conduit

Edwardsport IGCC Power Plant

How to design data center electrical and power systems

Data Center Process Cooling

Cooling Towers Offer Water and Energy Savings as Part of Efficient Data Center Cooling Systems

Picking software to model electrical systems

ALWAYS On | ALWAYS Reliable | ALWAYS Mission Critical

Know when, how to specify a rooftop unit



The performance of wall hoods can be improved by extending the bottom of the hood down below the interior wall opening. Roof hoods should not be located directly above generators. In addition to the increased potential for roof leaks, in some cases, a mist of water drawn through the hood can damage an electronic component and cause generator failure.

**Plenums**—Plenums are a highly effective method of protecting air inlets and outlets for generator rooms. The plenums are typically constructed at both ends of the generator room and consist of enclosed outer walls with an open top covered by grating. The outer plenum walls should be constructed of masonry or other durable construction to protect the air inlets/outlets. The inner wall of the building will still include intake and exhaust louvers, typically drainable blade.

Air enters at the top of the plenum on the intake side, passes through the intake louver and across the generator. The air then passes through the radiator fan and across the exhaust louver into the plenum and discharges out of the top of the exhaust plenum. The outer plenum wall blocks wind-driven rain from entering the building, mitigates the potential for wind pressure to cause back pressure on the radiator fan and protects against windborne debris. The drainable blade louver mitigates potential water penetration from vertical rainfall entering the top of the plenum. Figure 5 shows the air flow path through the plenum, as well as a representation of the plenum wall blocking wind-driven rain and windborne debris.

Although not directly tied to severe weather protection, there are other benefits of a plenum design. The plenum design has been shown to greatly reduce sound transmission by redirecting noise, so it dissipates before reaching the site boundary. For

### How to design standby power systems to withstand storms

Fiberglass Conduit VS PVC Conduit

Edwardsport IGCC Power Plant

How to design data center electrical and power systems

Data Center Process Cooling

Cooling Towers Offer Water and Energy Savings as Part of Efficient Data Center Cooling Systems

Picking software to model electrical systems

ALWAYS On | ALWAYS Reliable | ALWAYS Mission Critical

Know when, how to specify a rooftop unit

example, a standby power system at a wastewater treatment plant in Tennessee that incorporated intake and exhaust plenums was shown to keep decibel levels relatively the same whether the generators were running.

The plenum design has advantages when trying to aesthetically blend these standby power system facilities into the surrounding area. The plenums put the large industrial-looking louvers on the interior side of the plenum space and provides a blank canvas on the outside of the plenum for blending the facility with either the aesthetics of the adjoining buildings on-site or the vernacular of the community.

### **Fueling systems**

For a generator to operate during severe weather, the fueling system must be designed to mitigate the impacts of severe weather. Fuel sources for generators include diesel, natural gas or propane. All three fuel sources are considered reliable. Both diesel storage and propane are readily available on-site fuel sources with fixed storage capacity.

Several factors should be considered when determining the amount of on-site fuel storage, including the critical nature of the facility and the ability to refill the storage tank during an emergency. Seventy-two hours is a common storage capacity for standby generators serving critical facilities, but storage capacity should not be less than 24 hours. Natural gas is readily available with no storage required; however, there is a possibility of service interruption in the supply of natural gas, primarily caused by severe weather or natural disasters.

Diesel fuel can be stored in sub-base fuel tanks (typically for outdoor enclosures only),

### **How to design standby power systems to withstand storms**

Fiberglass Conduit VS PVC Conduit

Edwardsport IGCC Power Plant

How to design data center electrical and power systems

Data Center Process Cooling

Cooling Towers Offer Water and Energy Savings as Part of Efficient Data Center Cooling Systems

Picking software to model electrical systems

ALWAYS On | ALWAYS Reliable | ALWAYS Mission Critical

Know when, how to specify a rooftop unit



## How to design standby power systems to withstand storms

exterior above-grade fuel tanks or exterior below-grade fuel tanks. Above-grade fuel tanks should be a minimum UL 142 double-wall tank to eliminate the need for installing the fuel tank in a separate containment area that can collect stormwater during severe weather. UL 2085 protected storage tanks provide fire resistance, impact resistance from vehicles and projectiles and ballistic resistance from firearms. This type of tank should be considered to provide additional protection for the fuel system during severe weather.

For outdoor enclosures with sub-base fuel tanks, UL 2085 construction will likely require a custom enclosure and tank that will increase cost. This customization may not be available with smaller generator sets. The top of the fuel storage tank should be located above the 100-year flood level or other local design condition. This will mitigate potential water intrusion into the tank and allow the tank to be refilled even if partially submerged.

The tanks should be secured to meet the code required wind loads and buoyancy forces. Fuel piping systems for

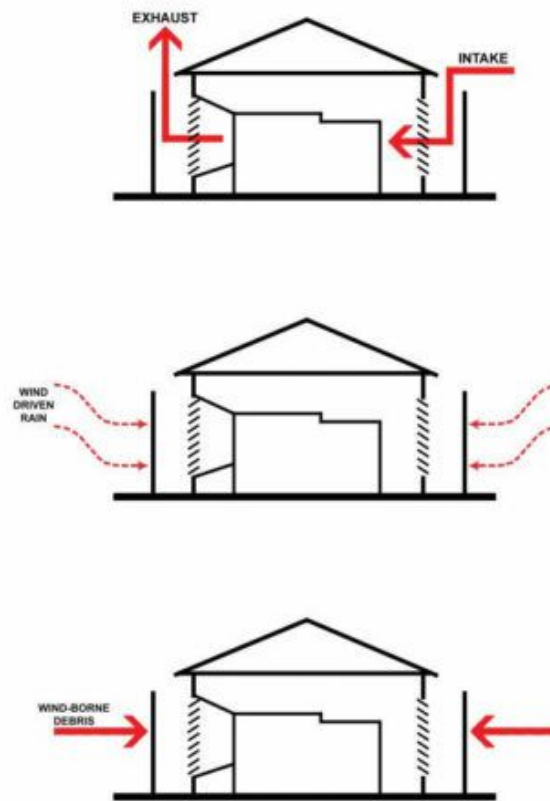

Figure 4 shows the airflow path through generator and how the plenum walls provide protection from wind driven rain, and wind-borne debris.

Figure 5: This shows schematic building sections with intake and exhaust plenums showing the air flow path through the plenums and generator, protection against wind-driven rain and protection against windborne debris.

Courtesy: CDM Smith

### How to design standby power systems to withstand storms

Fiberglass Conduit VS PVC Conduit

Edwardsport IGCC Power Plant

How to design data center electrical and power systems

Data Center Process Cooling

Cooling Towers Offer Water and Energy Savings as Part of Efficient Data Center Cooling Systems

Picking software to model electrical systems

ALWAYS On | ALWAYS Reliable | ALWAYS Mission Critical

Know when, how to specify a rooftop unit



**CHAMPION FIBERGLASS CONDUIT.**  
**TOUGH. STRONG. PROTECTIVE.**  
**SECURING DATA CENTERS FROM THE GROUND UP.**

**CHAMPION FIBERGLASS**

**Champion Fiberglass elbows:**

- Eliminate burn-through which prevents costly repairs
- Offer a low coefficient of friction for fast, smooth pulls
- Resist faults for easy pull-through

**Learn more at [championfiberglass.com](http://championfiberglass.com)**

**UL LISTED** **MADE IN THE USA**

separate above-grade fuel tanks should be secured to meet the project wind loads and piping should be laid out to minimize the length of exterior piping. Screen walls and protective pipe covers can be used to minimize potential for damage from windborne debris. Below-grade piping systems are another potential option, and will require double-wall piping and leak monitoring. Diesel fuel has a limited storage life and fuel quality will degrade with time and temperature. Fuel polishing systems should be considered for larger storage systems

Below-grade fuel tanks are not as common for standby generator applications due to additional regulatory requirements, but may be considered on a case-by-case basis if there are space constraints or aesthetic concerns, for example. Tanks should be double-wall and secured to resist buoyancy forces.

### How to design standby power systems to withstand storms

Fiberglass Conduit VS PVC Conduit

Edwardsport IGCC Power Plant

How to design data center electrical and power systems

Data Center Process Cooling

Cooling Towers Offer Water and Energy Savings as Part of Efficient Data Center Cooling Systems

Picking software to model electrical systems

ALWAYS On | ALWAYS Reliable | ALWAYS Mission Critical

Know when, how to specify a rooftop unit



# How to design standby power systems to withstand storms



## NO PVC? NO PROBLEM!

As the PVC shortage continues, Champion Fiberglass® has short lead times and competitive pricing to keep projects on track.

### Across many applications, projects using fiberglass conduit benefit from:

- Lower installation costs
- Light weight
- Superior compression and impact strength

Choose Champion Fiberglass electrical conduit instead of PVC conduit today.



BIM/Revit Models Available Now  
Visit [championfiberglass.com](http://championfiberglass.com)

MADE IN THE USA MasterSpec

020421

separate above-grade fuel tanks should be secured to meet the project wind loads and piping should be laid out to minimize the length of exterior piping. Screen walls and protective pipe covers can be used to minimize potential for damage from windborne debris. Below-grade piping systems are another potential option, and will require double-wall piping and leak monitoring. Diesel fuel has a limited storage life and fuel quality will degrade with time and temperature. Fuel polishing systems should be considered for larger storage systems

Below-grade fuel tanks are not as common for standby generator applications due to additional regulatory requirements, but may be considered on a case-by-case basis if there are space constraints or aesthetic concerns, for example. Tanks should be double-wall and secured to resist buoyancy forces.

## How to design standby power systems to withstand storms

Fiberglass Conduit VS PVC Conduit

Edwardsport IGCC Power Plant

How to design data center electrical and power systems

Data Center Process Cooling

Cooling Towers Offer Water and Energy Savings as Part of Efficient Data Center Cooling Systems

Picking software to model electrical systems

ALWAYS On | ALWAYS Reliable | ALWAYS Mission Critical

Know when, how to specify a rooftop unit

Ground monitoring stations may be required by local codes. The normal fill port may be submerged during severe weather, so an above-grade remote fill station should be considered.

Natural gas and propane generators produce fewer emissions than diesel generators. Natural gas generators require a feed from the local utility. The gas meter and pressure regulator(s) should be located above the 100-year flood level or other local design condition. Propane gas generators require above grade or below-grade storage tanks and interconnecting gas piping between the tank and generator. Installation requirements are similar to diesel fuel storage tanks, but there is not a similar “protected” storage tank construction standard available.

The concepts of weather hardening generator installations can be applied to other mission critical facilities like hospitals, fire stations and police stations; noncritical commercial and industrial facilities; and even residential construction. The design consultant, building owner and end user should work together to determine the best method to provide reliable standby power for each application.

### **Paul Pouliot and Michael T. Alford**

**Paul Pouliot** is a mechanical engineer with CDM Smith. Pouliot has 26 years of professional experience designing HVAC, plumbing, fire protection and fueling systems for numerous industrial, municipal and commercial projects. **Michael T. Alford** is an associate, architectural discipline leader with CDM Smith. Alford has 22 years of professional experience in architectural programming, planning, design and construction and has prepared design and construction documents for numerous industrial, municipal and commercial projects.

## How to design standby power systems to withstand storms

Fiberglass Conduit VS PVC Conduit

Edwardsport IGCC Power Plant

How to design data center electrical and power systems

Data Center Process Cooling

Cooling Towers Offer Water and Energy Savings as Part of Efficient Data Center Cooling Systems

Picking software to model electrical systems

ALWAYS On | ALWAYS Reliable | ALWAYS Mission Critical

Know when, how to specify a rooftop unit



**NO PVC?  
NO PROBLEM.**



## Fiberglass Conduit VS PVC Conduit

How to design standby power systems to withstand storms

### Fiberglass Conduit VS PVC Conduit

Edwardsport IGCC Power Plant

How to design data center electrical and power systems

Data Center Process Cooling

Cooling Towers Offer Water and Energy Savings as Part of Efficient Data Center Cooling Systems

Picking software to model electrical systems

ALWAYS On | ALWAYS Reliable | ALWAYS Mission Critical

Know when, how to specify a rooftop unit



# Edwardsport IGCC Power Plant

## **PROJECT NAME**

Edwardsport IGCC Power Plant

## **APPLICATION**

Utilities

## **CHAMPION FIBERGLASS PRODUCT(S)**

Champion Duct Reinforced  
Thermosetting Resin Conduit (RTRC)



**D**uke Energy's Edwardsport IGCC plant, located in Knox County, Indiana, is one of the cleanest and most efficient coal-fired power generating facilities in the world. Beginning commercial operations in 2013, the 618-mega-watt facility replaced an outdated coal-fired facility located on the same site – and at full capacity will generate enough energy to power approximately a half million homes.

## **Challenge**

For the facility, the project's contractor trenched a duct bank approximately two miles long to accommodate thousands of feet of electrical cables. SCH80 PVC conduit was originally specified for the project, requiring the purchase and installation of large, expensive underground concrete vaults in the duct bank every 250 ft. The project's engineers determined this distance between the vaults would

be necessary to prevent the cable from becoming damaged during pull-through because of PVC conduit's coefficient of friction. To implement a costs-savings solution, the project's engineers needed a conduit with a lower coefficient of friction than PVC to extend the distance between the vaults. This is where Champion Fiberglass came in.

### **Solution**

Duke project engineers chose Champion Duct® reinforced thermosetting resin conduit for their project. With its extremely low coefficient of friction, the distance between the concrete vaults was extended up to every 750 ft. in the duct bank. And thanks to Champion's underground rated gasket joining connection system – the contractor didn't have to commit any additional labor resources to epoxy together the conduit sections. In addition to the low coefficient of friction benefits, Champion RTRC conduit also provided protection against expensive cable faults being the conduit is "fault resistant". This benefit allowed the design engineers to maintain spare conduit runs for future expansion rather than accommodate for cable faults.

### **Results**

By eliminating approximately multiple concrete vaults at an average cost of \$275,000 each, the project benefited from approximately \$3 million in cost savings. Also, by avoiding the task of bonding conduit together with epoxy adhesive – the contractor realized even greater installation efficiency and reduced labor and material costs. Ultimately, Champion Duct mitigated potential damage to the cable during pull-through—ensuring against and preventing costly cable fault issues and guaranteeing a cost-effective result for the client.

How to design standby power systems to withstand storms

Fiberglass Conduit VS PVC Conduit

**Edwardsport IGCC Power Plant**

How to design data center electrical and power systems

Data Center Process Cooling

Cooling Towers Offer Water and Energy Savings as Part of Efficient Data Center Cooling Systems

Picking software to model electrical systems

ALWAYS On | ALWAYS Reliable | ALWAYS Mission Critical

Know when, how to specify a rooftop unit

# How to design data center electrical and power systems

*An expert panel provides engineering and design tips for electrical, power and lighting systems in this Q&A*



*Peter Czerwinski, PE, Uptime ATD, Mechanical Engineer/Mission Critical Technologist, Jacobs, Pittsburgh; Garr Di Salvo, PE, LEED AP, Associate Principal – Americas Data Center Leader, Arup, New York; Scott Gatewood, PE, Electrical Engineer/Project Manager, Regional Energy Sector Leader, DLR Group, Omaha, Neb.; Brian Rener, PE, LEED AP, Mission Critical Leader, SmithGroup, Chicago. Courtesy: Jacobs, Arup, DLR Group, SmithGroup*

How to design standby power systems to withstand storms

Fiberglass Conduit VS PVC Conduit

Edwardsport IGCC Power Plant

## How to design data center electrical and power systems

Data Center Process Cooling

Cooling Towers Offer Water and Energy Savings as Part of Efficient Data Center Cooling Systems

Picking software to model electrical systems

ALWAYS On | ALWAYS Reliable | ALWAYS Mission Critical

Know when, how to specify a rooftop unit



### Are there any issues unique to designing electrical/power systems for these types of facilities?

**BRIAN RENER:** The amount of power and the reliability are unlike most other facilities. The fast deployment timelines of many of these mission critical facilities requires the electrical engineer to quickly design and specify primary equipment and their space needs and often prepare to purchase this equipment due to the long lead manufacturing times for this equipment. Also, very early conversation and planning is essential with the local utility power company to determine the capacity and sources of power to the site.

**PETER CZERWINSKI:** Although standby generators are a common feature of data centers, the startup time for the generators must be considered when deciding which cooling components to put on uninterruptible power supply power. If generators take several seconds to start and apply power, that is time that chilled water pumps could shut off and fans could ramp down, possibly allowing the data hall's air temperature to increase above the desired limit.

**SCOTT GATEWOOD:** The uniqueness of electrical design infrastructure for data center designs might cluster around four factors: Concurrently maintainable, resilient, physically separate and expandable. Insuring independently produced power flows while servicing or replacing equipment that, should it fail, it does no harm but to itself and remain expandable for future efficient power flows, is an artform. Sure, there is a great deal more here but accomplishing these feats puts the cost within budget constraints.

### What types of unusual standby, emergency or backup power systems have you specified for data centers?

How to design standby power systems to withstand storms

Fiberglass Conduit VS PVC Conduit

Edwardsport IGCC Power Plant

### How to design data center electrical and power systems

Data Center Process Cooling

Cooling Towers Offer Water and Energy Savings as Part of Efficient Data Center Cooling Systems

Picking software to model electrical systems

ALWAYS On | ALWAYS Reliable | ALWAYS Mission Critical

Know when, how to specify a rooftop unit

**BRIAN RENER:** Diesel generators have long been the backbone of data centers. As power demands have risen, we have seen the size of the generators continue to rise. This not only includes the size but the use of paralleling and also medium-voltage rated generators. However, sustainability is driving the need for more environmentally friendly solutions, which at times includes consideration of natural gas generators and most recently even large-scale utility grade and utility interactive battery systems as alternatives to generators.

**GARR DI SALVO:** One of the areas where we've seen the greatest diversity in approach is in ensuring smooth and continuous power to IT equipment. The best accepted criterion for power continuity is the Information Technology Industry Council curve, which describes the tolerance of PC power supplies to voltage sags and the equipment supply. UPSs provide capacity to ride through utility voltage dips and outages (allowing for startup of standby power systems). Although in-rack backup power can help reduce common mode failures and Day One costs, centralized solutions are more common. Double-conversion UPS are prevalent in North America, whereas rotary and diesel rotary systems are more common in the rest of the world. One interesting deployment we've seen involved a hybrid system that employs rotary UPSs along with batteries to extend the ride-through capabilities.

### **What are some key differences in electrical, lighting and power systems you might incorporate in this kind of facility, compared to other projects?**

**PETER CZERWINSKI:** Equipment yards in data centers commonly contain rows of isolated pieces of equipment that may cause shadows and blind spots at night. Care

How to design standby power systems to withstand storms

Fiberglass Conduit VS PVC Conduit

Edwardsport IGCC Power Plant

### **How to design data center electrical and power systems**

Data Center Process Cooling

Cooling Towers Offer Water and Energy Savings as Part of Efficient Data Center Cooling Systems

Picking software to model electrical systems

ALWAYS On | ALWAYS Reliable | ALWAYS Mission Critical

Know when, how to specify a rooftop unit

must be taken to design exterior lighting to meet code and safety requirements. Consider specifying lighting to be installed on the equipment by the equipment manufacturers.

**How does your team work with the architect, owner's rep and other project team members so the electrical/power systems are flexible and sustainable? "**

**BRIAN RENER:** It is important to work closely with the client and their IT professionals to understand the phased implementation and growth of the computer equipment so that the right "modules" of electrical power can be designed. These power modules must be designed and installed to allow the owner to grow their load without interruption of any previously installed data center systems.

"Resilient" or "resiliency" is a buzzword when discussing data centers. What are owners requesting to make the building meet resiliency goals? How are you designing data centers to be more resilient?



*As power demands rise in data centers, the size of the generators continues to rise. This not only includes the size but the use of paralleling generators.  
Courtesy: SmithGroup*

How to design standby power systems to withstand storms

Fiberglass Conduit VS PVC Conduit

Edwardsport IGCC Power Plant

**How to design data center electrical and power systems**

Data Center Process Cooling

Cooling Towers Offer Water and Energy Savings as Part of Efficient Data Center Cooling Systems

Picking software to model electrical systems

ALWAYS On | ALWAYS Reliable | ALWAYS Mission Critical

Know when, how to specify a rooftop unit



**SCOTT GATEWOOD:** Resiliency can apply to every facet of infrastructure design including the serving utilities, the security perimeters, the building envelope and physical program spaces. Literally, every element can be evaluated for its threat to operational integrity. Carefully asking after and listening to the client's goals and infrastructure risk tolerances is a primary goal.

**PETER CZERWINSKI:** Standards such as Uptime Institute and TIA-942 are straightforward road maps on how to achieve a desired level of resiliency. Sometimes a data center owner requires a Tier II minimum resiliency, but still wants to implement certain features found in Tier III facilities. Certain power and cooling technologies are easier and less expensive to achieve Tier III's concurrent maintainability with than others.

**GARR DI SALVO:** The industry's view of resiliency has become much more sophisticated over the course of my career. Reliability is still a critical design criterion but competes with others, like time-to-market and life cycle costs. Owners are now looking beyond simple stratagems like Tier III, system plus system or distributed redundant in system architecture. Instead, they're seeking tangible justification for design decisions. In response to this, we've incorporated probabilistic modeling of building system availability as a supplement to point of failure and fault tree analysis techniques.

**BRIAN RENER:** Climate change is on the minds of many data center owners. We are seeing records for flooding and unusually high temperature and also low temperature "design days" as we saw this winter in Texas. You want the facility and the electrical power systems designed to accommodate these new environmental stresses. This may mean things as simple as designing to a 500-year flood or increased utility outage times.

How to design standby power systems to withstand storms

Fiberglass Conduit VS PVC Conduit

Edwardsport IGCC Power Plant

### How to design data center electrical and power systems

Data Center Process Cooling

Cooling Towers Offer Water and Energy Savings as Part of Efficient Data Center Cooling Systems

Picking software to model electrical systems

ALWAYS On | ALWAYS Reliable | ALWAYS Mission Critical

Know when, how to specify a rooftop unit

### **When designing lighting systems for these types of structures, what design factors are being requested? Are there any particular technical advantages that are or need to be considered?**

**SCOTT GATEWOOD:** Lighting design factors requested for data halls balance efficiency for the task at hand with getting light levels deep within the cabinet rows. Typically, operational light levels can be low (20 foot candles) for typical management. However, for buildings, light levels should be elevated (50 foot candles) to permit detailed tasks deep within cabinets where indirect illumination is nearly zero due to the tall cabinets and supporting infrastructure above. Consequently, luminaires nearer to the cabinet elevation are optimal.

**GARR DI SALVO:** With the wide variety of solutions available on the market, it's easy to specify high-efficiency lighting fixtures to meet code and operational requirements. Standalone and integrated system sensors can further optimize energy efficiency, providing a "lights out" facility. Some locales have requirements for daylighting. Despite its many advantages, security and climate control concerns may make the introduction of natural light undesirable.

At least as important is ensuring consistent and adequate white space illumination, both to ensure a safe working environment but also to improve productivity (as much as 9% in some studies). Data centers often have many overhead elements. These require careful coordination during construction to minimize and eliminate shadows at the work plane, both in the data hall and in back of house support spaces.

**Consulting-Specifying Engineer**

How to design standby power systems to withstand storms

Fiberglass Conduit VS PVC Conduit

Edwardsport IGCC Power Plant

### **How to design data center electrical and power systems**

Data Center Process Cooling

Cooling Towers Offer Water and Energy Savings as Part of Efficient Data Center Cooling Systems

Picking software to model electrical systems

ALWAYS On | ALWAYS Reliable | ALWAYS Mission Critical

Know when, how to specify a rooftop unit



MARLEY

## Factors to consider in cooling system design:



Construction and commissioning schedules



Reliability and ease of maintenance



Efficiency and water management



Quality



Cost

## Evaporative Cooling Advantages for Mission Critical Facilities

**SPX Cooling Technologies** has unique manufacturing capabilities that ensure Marley Cooling Towers are engineered and built to address the specific requirements of mission-critical facilities. Factory-assembled cooling towers can be delivered up to 60% faster and installed up to 80% faster compared with field-constructed alternatives.

Compared with air-cooled alternatives, evaporative cooling offers greater energy efficiency and lower water consumption for data centers. In addition, lifetime operational costs make **Marley Cooling Towers** a wise investment - easy to monitor and maintain, providing reliable cooling for data centers over decades. As data centers scale up, Marley modular cooling towers allow operators to easily add capacity as facilities expand.

**Get started today!**

[www.spxcooling.com/applications/data-centers](http://www.spxcooling.com/applications/data-centers)



Follow us on social media: [spxcooling.com/connect](http://spxcooling.com/connect)

800.4.Marley | [spxcooling.com](http://spxcooling.com)

COPYRIGHT © 2021 SPX Cooling Technologies, Inc. All rights reserved.

**SPX**





## Data Center Process Cooling

*The massive computing power within data centers generates heat, making efficient cooling a key building system requirement. Evaporative cooling towers are an integral part of many data center cooling systems.*

How to design standby power systems to withstand storms

Fiberglass Conduit VS PVC Conduit

Edwardsport IGCC Power Plant

How to design data center electrical and power systems

### Data Center Process Cooling

Cooling Towers Offer Water and Energy Savings as Part of Efficient Data Center Cooling Systems

Picking software to model electrical systems

ALWAYS On | ALWAYS Reliable | ALWAYS Mission Critical

Know when, how to specify a rooftop unit

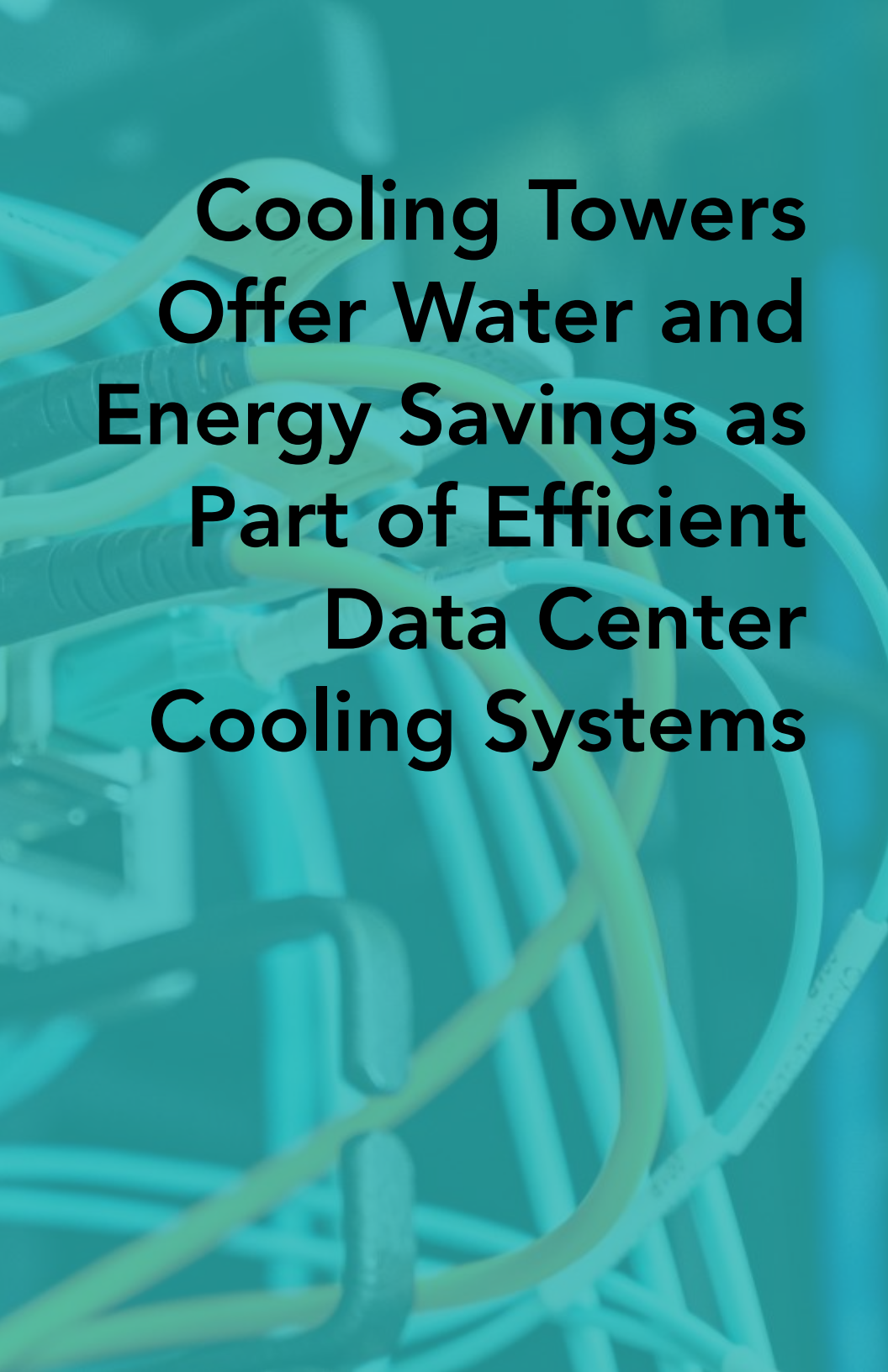

# Cooling Towers Offer Water and Energy Savings as Part of Efficient Data Center Cooling Systems

The number of data centers in the United States continues to grow in response to the enormous amount of digital information stored and streamed. The massive computer power within these data centers generates heat, making efficient cooling a key building system requirement. Evaporative cooling towers are an integral part of many data center cooling systems.

Recently some have questioned the use of cooling towers, citing water scarcity to bolster their arguments. But a thorough examination of water use for local onsite cooling towers compared to water use to generate power at regional fossil fuel power plants reveals surprising results.

## **Data center cooling options**

There are multiple ways to cool data centers, depending on the size, computer capacity that must be cooled, regional energy costs and the data load and density. Popular options include:

- Water-cooled chiller plant – includes chiller system, pumps, cooling tower and plate/frame heat exchanger in series with the chiller
- Air-cooled chiller plant – includes chiller system and pumps

## Cooling Towers Offer Water and Energy Savings as Part of Efficient Data

- Direct evaporative cooling – without mechanical refrigeration, also referred to as “swamp cooling”
- Adiabatic cooling – air-cooled system assisted by water-cooled system during peak conditions



*Evaporative cooling towers are an integral part of many data center cooling systems, depending on their location.*

To attract customers, data center operators weigh the options and look for systems that reduce operating costs and environmental impact. They pay close attention to power use effectiveness (PUE), defined as the ratio of the total amount of energy used by a data center to the energy delivered to the computing equipment. A PUE of 1 means the heat rejection power equals the power used for the computing equipment.

Data center operators are also concerned about water use effectiveness (WUE). Cooling towers evaporate water, but the impact depends on location. According to Tim Chiddix, PE, VP Mechanical Engineering at Swanson Rink, a leader in the design of data center facility infrastructure, data centers can range from a few hundred square feet to several hundred thousand square feet and no cooling technology works well for

How to design standby power systems to withstand storms

Fiberglass Conduit VS PVC Conduit

Edwardsport IGCC Power Plant

How to design data center electrical and power systems

Data Center Process Cooling

### Cooling Towers Offer Water and Energy Savings as Part of Efficient Data Center Cooling Systems

Picking software to model electrical systems

ALWAYS On | ALWAYS Reliable | ALWAYS Mission Critical

Know when, how to specify a rooftop unit



## Cooling Towers Offer Water and Energy Savings as Part of Efficient Data

all regions, client criteria and applications. "Each and every facility must be analyzed to determine the approach that best meets the needs of the customer and takes advantage of energy and water savings opportunities of the particular region."

Swanson Rink specifies equipment as part of its data center practice and frequently combines cooling towers with mechanical chillers for efficient cooling.

### Water use issues must be evaluated holistically

The extended drought throughout the Western states has caused many companies to reexamine the impact of water usage for cooling data centers. Some have questioned whether onsite cooling towers use too much water given these shortages. In evaluating the best cooling strategy for a data center, it is critical to view water usage holistically, including water use where the power is made. When viewed in this light, mechanical evaporative cooling systems are often far more efficient than alternative dry systems.



*Mechanical evaporative systems are often more efficient than dry systems, reducing water usage at power plants.*

How to design standby power systems to withstand storms

Fiberglass Conduit VS PVC Conduit

Edwardsport IGCC Power Plant

How to design data center electrical and power systems

Data Center Process Cooling

### Cooling Towers Offer Water and Energy Savings as Part of Efficient Data Center Cooling Systems

Picking software to model electrical systems

ALWAYS On | ALWAYS Reliable | ALWAYS Mission Critical

Know when, how to specify a rooftop unit

## Cooling Towers Offer Water and Energy Savings as Part of Efficient Data

---

The amount of water used by the steam cycle of a fossil-fuel based power plant to generate electricity may be greater than the amount of water used by the data center cooling tower. An example is an air-cooled system that uses 1 megawatt (MW) of power per year compared with a water cooled system that uses 0.5 MW per year and 3,000 gallons of water per minute. The number of gallons the power plant uses to make the additional 0.5 MW to power the air-cooled system is actually greater than the amount of water that would be used locally by the water cooled system's cooling tower. Cutting down the energy used from power plants may actually save water.

Swanson Rink's Tim Chiddix and Brook Zion evaluated the water use issue in a white paper, *Data Center Water Usage for Denver, Phoenix and Los Angeles: A Look at the big picture*. Chiddix and Zion examined whether reduction in water use at an individual data center facility results in an aggregate reduction in water use for the regional water supply system.

The authors note that water is a more efficient medium than air for removing heat because evaporation enhances the cooling process. "Using water-cooled condensing systems versus air-cooled condensing systems can significantly reduce your cooling energy costs; however the effectiveness of evaporative cooling is very location-dependent, since the drier climate results in greater efficiency."

They studied whether this energy reduction comes with an increase in onsite water usage due to evaporation. They also considered whether this evaporation is wasting water and whether data center owners should consider air-cooled equipment instead. The evaluation compared sample data centers located in Denver, Phoenix and Los

How to design standby power systems to withstand storms

Fiberglass Conduit VS PVC Conduit

Edwardsport IGCC Power Plant

How to design data center electrical and power systems

Data Center Process Cooling

### Cooling Towers Offer Water and Energy Savings as Part of Efficient Data Center Cooling Systems

Picking software to model electrical systems

ALWAYS On | ALWAYS Reliable | ALWAYS Mission Critical

Know when, how to specify a rooftop unit

Angeles. It examined the regional power grid to determine how much water the power companies consume to produce a kilowatt-hour (kWh) of power. Water consumption rate data from the National Renewable Energy Laboratory (NREL) technical report TP-550-33906<sup>1</sup> is shown in Table 1.

**TABLE 1**  
**Average Water Consumption at Power Plants**

State	Gallons/kWh
Colorado	1.20
Arizona	7.88
California	4.64

The study looked at cooling for a sample data center with a steady 1,500 kW cooling load. The authors compared a standard efficiency water-cooled chiller system and a standard efficiency air-cooled chiller system, as well as an evaporative system with no mechanical cooling. The water-cooled plant includes a chiller system, pumps, cooling tower and plate/frame heat exchanger in series with the chiller. The air-cooled chiller includes the chiller system and pumps. Table 2 shows the full load power consumption of the air-cooled chiller was significantly higher than that of the water-cooled chiller.

Water use, through evaporation, was based on dry-bulb and wet-bulb temperature data from a Typical Meteorological Year (TMY3) obtained from the National Solar Radiation Data Base (NSRDB).<sup>2</sup> The authors found that the water-cooled chiller system

**TABLE 2**  
**Full Load Chiller Power Consumption**

Chiller Type	Denver (kW/Ton)	Phoenix (kW/Ton)	Los Angeles (kW/Ton)
Air-cooled	1.250	1.340	1.250
Water-cooled	0.431	0.462	0.426

How to design standby power systems to withstand storms

Fiberglass Conduit VS PVC Conduit

Edwardsport IGCC Power Plant

How to design data center electrical and power systems

Data Center Process Cooling

**Cooling Towers Offer Water and Energy Savings as Part of Efficient Data Center Cooling Systems**

Picking software to model electrical systems

ALWAYS On | ALWAYS Reliable | ALWAYS Mission Critical

Know when, how to specify a rooftop unit



## Cooling Towers Offer Water and Energy Savings as Part of Efficient Data

in Denver consumed 1,610,748 kWh of energy and the air-cooled chiller system consumed 4,663,740 kWh annually.

Figure 1 shows the energy and water usage for the mechanical chiller systems analyzed in each city. Water use shows significant differences

because the amount of water consumed at the power generation facilities is far greater than water consumed on site.

The air-cooled chiller system consumes more power and evaporates no water on site. All of its water use is at the rate of power plant water consumption. By contrast, the water-cooled chiller has lower power consumption and a combination of onsite and power plant water consumption.

According to Chiddix, municipalities requiring data centers to use less energy and water onsite may not have considered the full implications of these requirements. In his opinion, if the power generating plant is considered in the equation, the cooling technologies selected for the data center may actually result in more overall energy and water use.



*Some systems can utilize "free cooling" or "water-side economizer" technology for higher efficiency.*

How to design standby power systems to withstand storms

Fiberglass Conduit VS PVC Conduit

Edwardsport IGCC Power Plant

How to design data center electrical and power systems

Data Center Process Cooling

**Cooling Towers Offer Water and Energy Savings as Part of Efficient Data Center Cooling Systems**

Picking software to model electrical systems

ALWAYS On | ALWAYS Reliable | ALWAYS Mission Critical

Know when, how to specify a rooftop unit

## Additional energy-saving factors to consider

Water-cooled technologies are more efficient, particularly when “free cooling” is employed during periods of cooler weather. Free cooling, also referred to as “water-side economizer” cooling, is an economic method of using low external air temperatures to assist in chilling water. When operating in free cooling mode, the water from the cooling tower is cold enough that mechanical refrigeration by the chiller is not required. This reduces the energy requirement significantly, typically by 75 percent or more. To take advantage of the energy savings possible with free cooling, there must be sufficient hours of cold weather to justify the

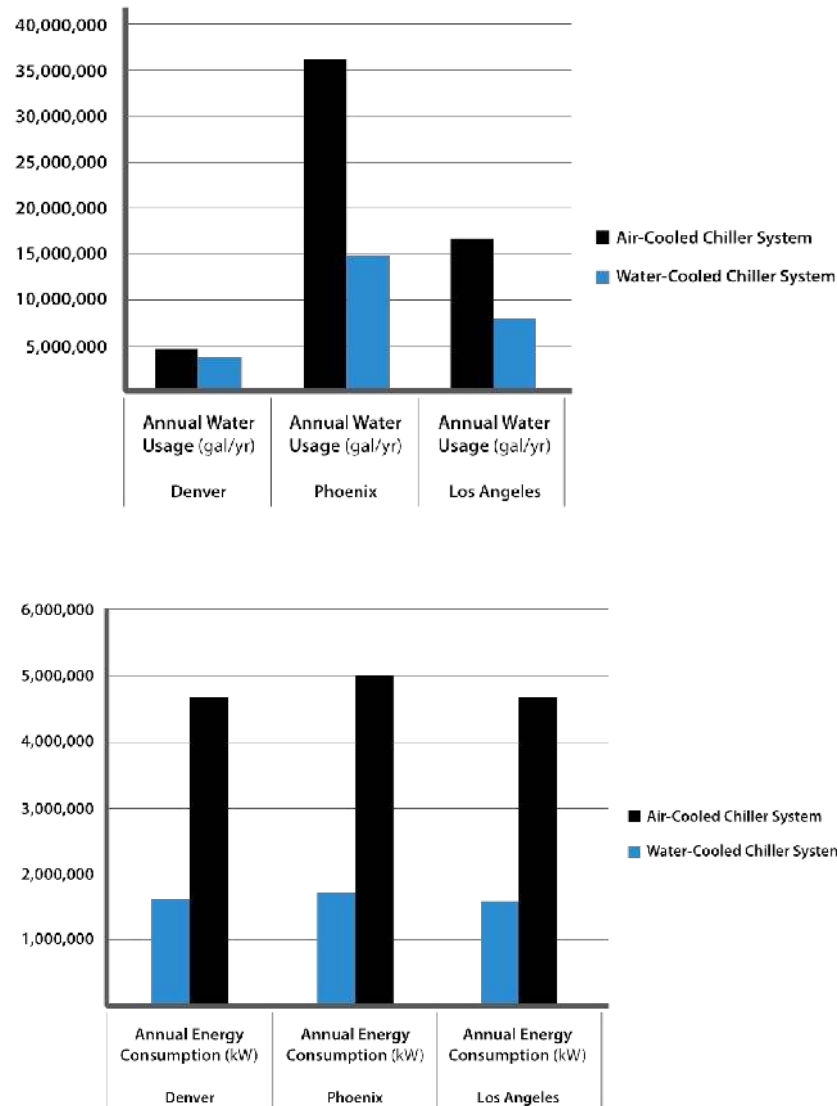

Figure 1 – Comparison of water and energy use in air-cooled and water-cooled chiller systems Source: Data Center Water Usage for Denver, Phoenix and Los Angeles: A Look at the big picture, by Tim Chiddix, PE, ATD and Brook Zion, PE, ATD

How to design standby power systems to withstand storms

Fiberglass Conduit VS PVC Conduit

Edwardsport IGCC Power Plant

How to design data center electrical and power systems

Data Center Process Cooling

## Cooling Towers Offer Water and Energy Savings as Part of Efficient Data Center Cooling Systems

Picking software to model electrical systems

ALWAYS On | ALWAYS Reliable | ALWAYS Mission Critical

Know when, how to specify a rooftop unit

additional equipment investment for the plate/frame heat exchanger and other components.

An evaluation of the benefits of cooling towers in data center cooling must also consider “variable flow,” another method to reduce energy consumption. Cooling towers are sized for summer design condition; variable flow enables users to reduce the water flow from the cooling tower to the chiller during cooler seasons. Fans are operated at a lower speed, which reduces energy usage. Taking advantage of free cooling and variable flow modes can dramatically reduce cooling tower energy use.

Cooling tower modularity provides another advantage. Data center owners may prefer to build out their facilities over time as server demand grows. To control initial capital expenditures and operating costs, data center operators may add cooling capacity lat-

**TABLE 3**  
**Data for cooling system comparison**

Sample 1,500 kW data center

	DENVER	PHOENIX	L.A.
	<b>Annual Energy Consumption (kW)</b>	<b>Annual Energy Consumption (kW)</b>	<b>Annual Energy Consumption (kW)</b>
Water Cooled Chiller	1,610,748	1,726,603	1,592,062
Air Cooled Chiller	4,663,470	4,999,089	4,663,470
<b>System</b>	<b>Annual Water Usage (gal/yr)</b>	<b>Annual Water Usage (gal/yr)</b>	<b>Annual Water Usage (gal/yr)</b>
Water Cooled Chiller	3,593,000	14,844,000	7,732,000
Air Cooled Chiller	4,645,000	36,182,000	16,640,000
<b>Difference</b>	<b>1,052,000</b>	<b>21,338,000</b>	<b>8,908,000</b>
<b>% Of Water Use Reduction</b>	<b>22.60%</b>	<b>59.00%</b>	<b>53.50%</b>

How to design standby power systems to withstand storms

Fiberglass Conduit VS PVC Conduit

Edwardsport IGCC Power Plant

How to design data center electrical and power systems

Data Center Process Cooling

## Cooling Towers Offer Water and Energy Savings as Part of Efficient Data Center Cooling Systems

Picking software to model electrical systems

ALWAYS On | ALWAYS Reliable | ALWAYS Mission Critical

Know when, how to specify a rooftop unit



er as needed by utilizing systems that incorporate factory-assembled modular cooling towers as the facility grows. It is important for data center construction to be completed on schedule so that servers can be operational quickly to generate revenue. Modular pre-assembled and field-erected cooling towers can meet time-sensitive delivery requirements and construction schedules.

### Weighing the water options

There are many combinations of evaporative and mechanical cooling solutions that can be evaluated to meet data center cooling requirements. As the discussion of water is added to the list of design considerations, it is important to understand and evaluate the relationship between utility power and local water consumption in order to make well-reasoned decisions for achieving energy and water conservation goals.

#### Paul Erlinger

**Paul Erlinger** is Global Business Development Manager – Data Centers for SPX Cooling Technologies, Inc.

<sup>1</sup> Torcellini, P., Long, N. and Judkoff, R. "Consumptive Water Use for U.S. Power Production." December 2003. Accessed October 31, 2016. <http://www.nrel.gov/docs/fy04osti/33905.pdf>

<sup>2</sup> National Renewable Energy Laboratory. "National Solar Radiation Data Base. 1991-2005 Update: Typical Meteorological Year 3." NREL.gov [http://rredc.nrel.gov/solar/old\\_data/nsrdb/1991-2005/tmy3/](http://rredc.nrel.gov/solar/old_data/nsrdb/1991-2005/tmy3/)

How to design standby power systems to withstand storms

Fiberglass Conduit VS PVC Conduit

Edwardsport IGCC Power Plant

How to design data center electrical and power systems

Data Center Process Cooling

**Cooling Towers Offer Water and Energy Savings as Part of Efficient Data Center Cooling Systems**

Picking software to model electrical systems

ALWAYS On | ALWAYS Reliable | ALWAYS Mission Critical

Know when, how to specify a rooftop unit

# Picking software to model electrical systems

*As electrical power and lighting systems become more complex, modeling for safe and reliable electrical operations becomes increasingly important*

**A**s electrical power system in facilities such as generation stations, industry complexes, hospitals, water pumping stations, water treatment plants, processing plants and other similar facilities expand and become more complex — specifically with integrating microgrid systems for system reliability and cost savings — electrical distribution system model development and proper system analyses become increasingly important.

These systems require advanced industrial electrical software tools for modeling and performing different studies, especially with the increasing availability of convertible equipment such as inverters, variable frequency drives and distributed energy resources such as photovoltaic and battery energy storage systems.

From the conceptual design to operating these complex systems, facility personnel must consider as it is a “living” entity that changes significantly over time as loads increase, equipment is replaced or upgraded, systems are enhanced or utility interconnection parameters change.

## **Electrical design, analysis software tools**

There are numerous industrial electrical system analysis software tools currently available for designers and engineers to analyze power systems, such as ETAP, SKM PowerTools, EasyPower, PowerWorld, PSS E, PSCAD, CYME, DIgSILENT. These tools are

How to design standby power systems to withstand storms

Fiberglass Conduit VS PVC Conduit

Edwardsport IGCC Power Plant

How to design data center electrical and power systems

Data Center Process Cooling

Cooling Towers Offer Water and Energy Savings as Part of Efficient Data Center Cooling Systems

## **Picking software to model electrical systems**

ALWAYS On | ALWAYS Reliable | ALWAYS Mission Critical

Know when, how to specify a rooftop unit

## Picking software to model electrical systems

capable of building complex electrical generation, distribution or transmission system models and performing a variety of system studies, such as load flow, motor starting and voltage stability, short circuit, protective device coordination and equipment protection, arc flash, harmonic, reliability, real time automation, control and monitoring.

In addition, there are available online software tools that can be used to perform, for example, equipment sizing calculations for generator sizing to verify the adequacy of existing or new generators under different loading conditions.

Electrical lighting design software such as agi32 and Elumtools by Lighting Analysts, Visual Lighting Software by Acuity Brands and DIALux by Dial Gmbh are a few commonly used suites used to perform lighting photometric calculations, daylighting simulations and lighting-based visual renderings.

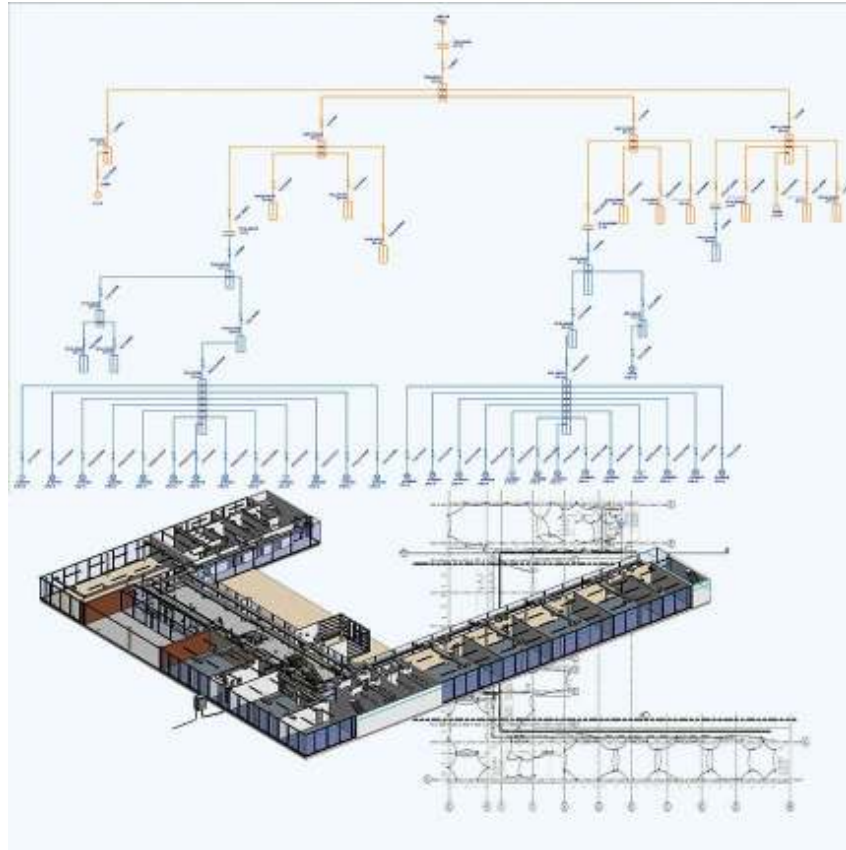

Figure 1: This shows the Autodesk Revit Electrical BIM design package with the ETAP modeling and analysis software tool.  
Courtesy: ETAP

How to design standby power systems to withstand storms

Fiberglass Conduit VS PVC Conduit

Edwardsport IGCC Power Plant

How to design data center electrical and power systems

Data Center Process Cooling

Cooling Towers Offer Water and Energy Savings as Part of Efficient Data Center Cooling Systems

### Picking software to model electrical systems

ALWAYS On | ALWAYS Reliable | ALWAYS Mission Critical

Know when, how to specify a rooftop unit



Lighting design software, such as Elumtools, allows designers to perform photometric calculations in the building information modeling application because designers are typically already using BIM to develop models and engineering drawings. This integration allows the lighting designer to seamlessly use model parameters input into the BIM model to perform lighting calculations.

In general, several of these electrical and lighting software packages such as ETAP, SKM PowerTools, EasyPower or Elumtools can integrate into BIM workflows. Used in conjunction with data exchange modules, these software options can exchange data with BIM modeling software, such as Autodesk Revit to maintain the overall integrated design approach and consistency.

These bi-directional data exchange packages simplify and reduce cost of the electrical design process in short and long terms by using the data that already exist in the Revit to automatically generate electrical models to perform electrical system study (see Figures 1 and 3) or use it to design and analyze lighting calculations.

### **Importance, selection of software**

Each facility may select or prefer to use any of the previously mentioned software or another software, based on:

- Specific application.
- Alternating current direct current or real-time module availability.
- Cost.
- Prior experience.
- Vendor support and training.

How to design standby power systems to withstand storms

Fiberglass Conduit VS PVC Conduit

Edwardsport IGCC Power Plant

How to design data center electrical and power systems

Data Center Process Cooling

Cooling Towers Offer Water and Energy Savings as Part of Efficient Data Center Cooling Systems

### **Picking software to model electrical systems**

ALWAYS On | ALWAYS Reliable | ALWAYS Mission Critical

Know when, how to specify a rooftop unit

## Picking software to model electrical systems

- Software quality programs.
- User friendliness.

It is difficult to properly evaluate the right software and its limitations without making significant labor and financial investments. Regardless of the electrical software used, it is important for a facility to have such a model available and to regularly maintain it. Having a facility model can help to identify electrical system limitations and issues, improve system reliability and personnel safety and helps engineers with variety of system modifications such as microgrid to provide an alternative source for reliable and cost-saving operation.

### Learning to use electrical design software

The following example illustrates the need for an electrical software tool to model and perform a feasibility study for integrating a microgrid into the existing facility and evaluate different system configurations. Note that for this study, no Revit integration is

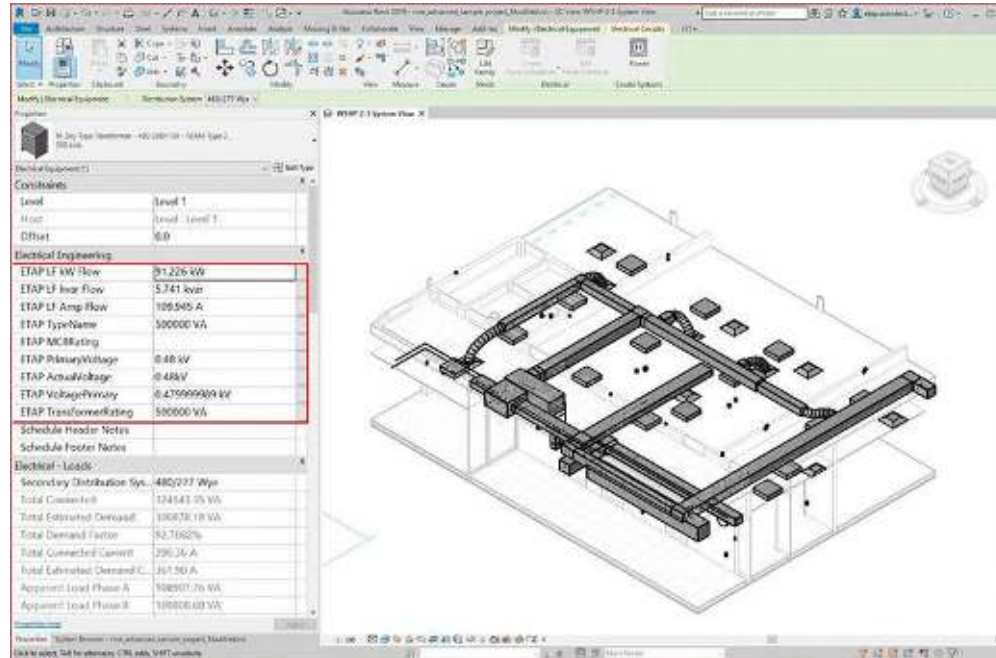

Figure 2: This highlights the Autodesk Revit Electrical BIM design package with electrical data exchanged by the ETAP modeling and analysis software tool.

Courtesy: ETAP

How to design standby power systems to withstand storms

Fiberglass Conduit VS PVC Conduit

Edwardsport IGCC Power Plant

How to design data center electrical and power systems

Data Center Process Cooling

Cooling Towers Offer Water and Energy Savings as Part of Efficient Data Center Cooling Systems

### Picking software to model electrical systems

ALWAYS On | ALWAYS Reliable | ALWAYS Mission Critical

Know when, how to specify a rooftop unit

## Picking software to model electrical systems

used due to the small facility size. Revit integration is typically applicable to much larger and complex system where it can offer more benefits.

This facility is fed from 13.2 kilovolt circuits via a single 1,000 kilovolt-amperes service transformer, an on-site 800 kilowatts backup generator and 500 kilowatts DER (including PV and BESS).

The DER is connected to utility system by a 500-kilowatt bi-directional inverter that can supply (from PV or BESS) or absorb (BESS charging) power. A simplified electrical system when the facility is fed from utility source is shown in Figure 4.

How much DER can support when the facility is in parallel or when is in island operation? What is the impact to the system parameters such as bus voltages?

One of the advantages of having a facility electrical system model is to evaluate different system conditions and scenarios. Having a model will expedite time and accu-

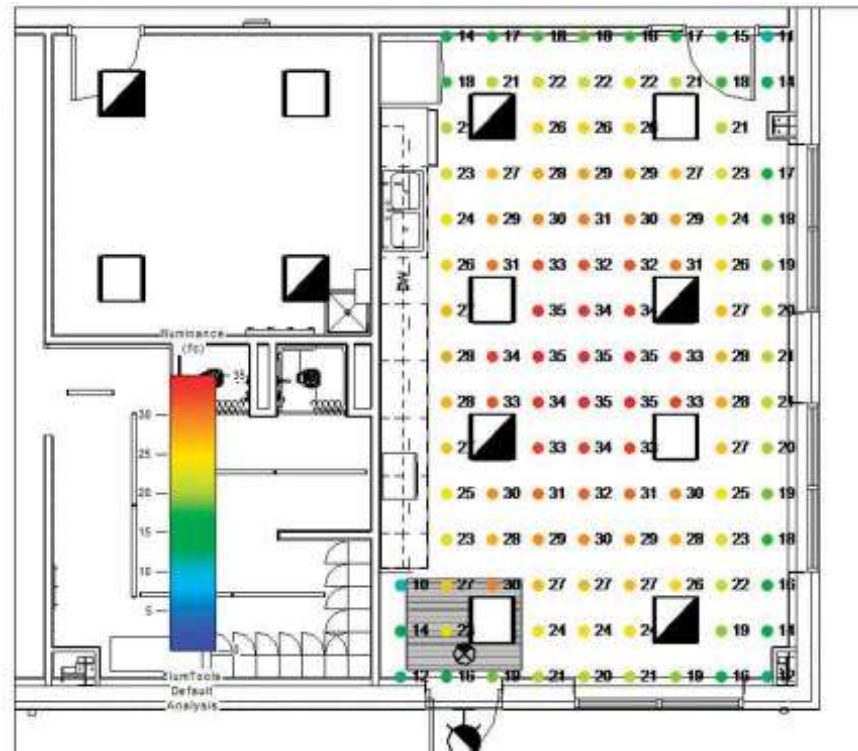

Figure 3: This shows a lighting photometric calculation using ElumTools fully lighting calculation add-in for Autodesk Revit. Courtesy: CDM Smith

How to design standby power systems to withstand storms

Fiberglass Conduit VS PVC Conduit

Edwardsport IGCC Power Plant

How to design data center electrical and power systems

Data Center Process Cooling

Cooling Towers Offer Water and Energy Savings as Part of Efficient Data Center Cooling Systems

## Picking software to model electrical systems

ALWAYS On | ALWAYS Reliable | ALWAYS Mission Critical

Know when, how to specify a rooftop unit



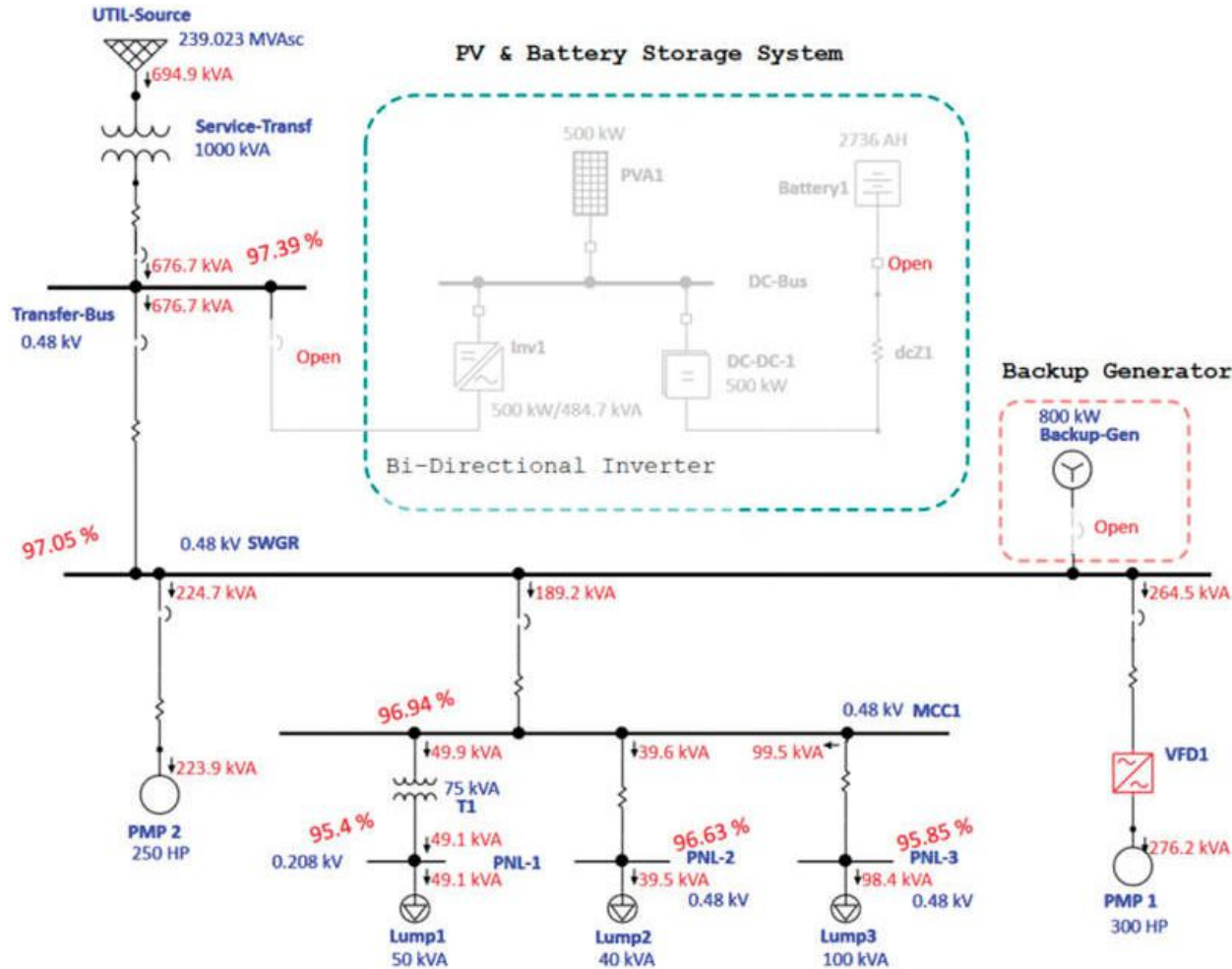

How to design standby power systems to withstand storms

Fiberglass Conduit VS PVC Conduit

Edwardsport IGCC Power Plant

How to design data center electrical and power systems

Data Center Process Cooling

Cooling Towers Offer Water and Energy Savings as Part of Efficient Data Center Cooling Systems

## Picking software to model electrical systems

ALWAYS On | ALWAYS Reliable | ALWAYS Mission Critical

Know when, how to specify a rooftop unit

racy to perform such modification and evaluate possible impact as far as system parameters such as power flow, available fault current, etc.

Figure 4: This shows an electrical distribution system ETAP model when a facility is fed power from the utility source only. Courtesy: CDM Smith

As shown in Figure 4, in this scenario, all demands are supplied from utility source with approximately 680 kilovolt-ampere demand including

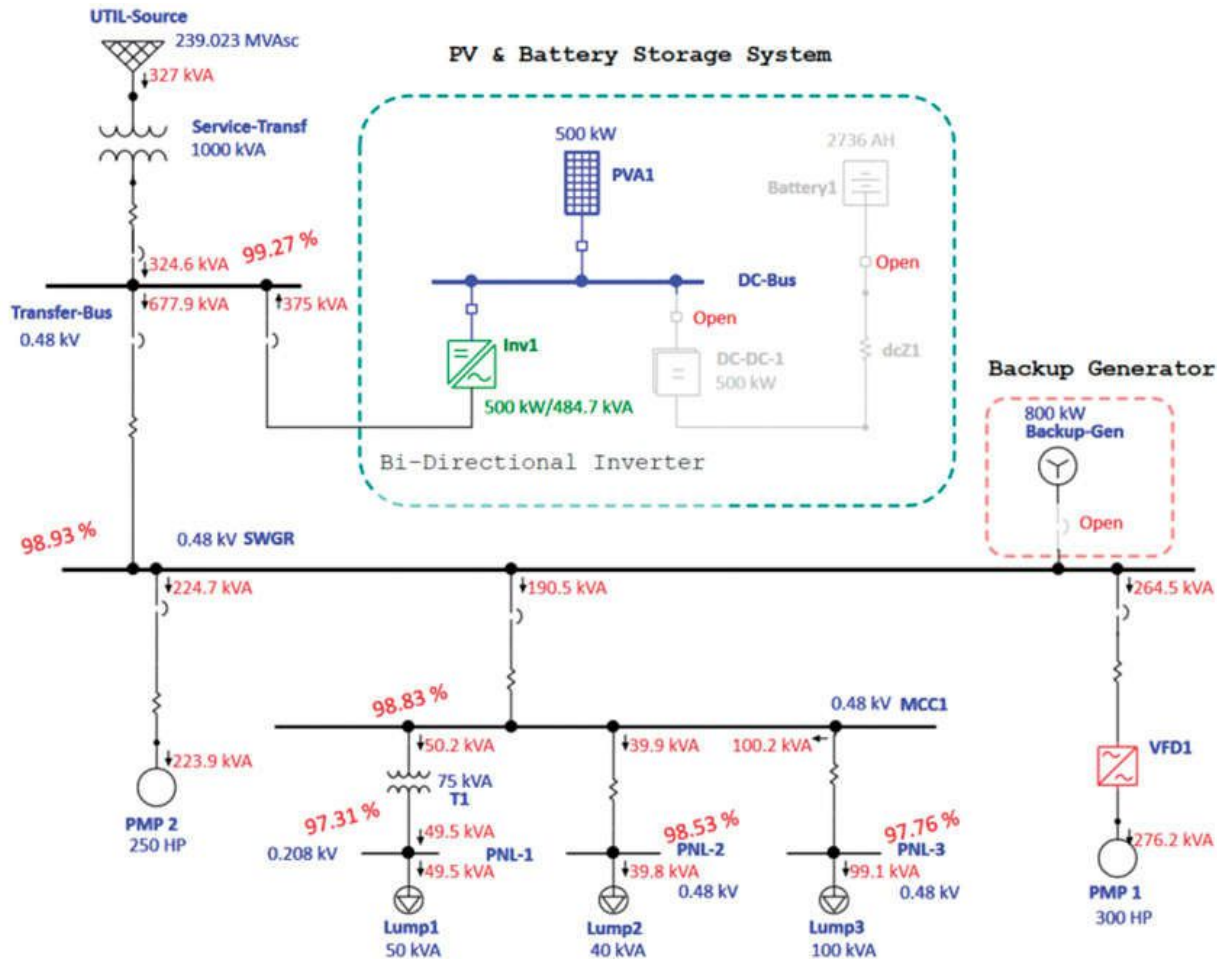

system voltages at each location.

When the DER (PV) is connected in parallel with the utility source, more than half a required demand, 375 kilovolt-ampere, is provided by this system that owns by the facility. This system can also be used as an alternative source when utility is disconnected (i.e., island operation). The load flow for this scenario is

Figure 5: In this example, an electrical distribution system ETAP model when a facility is fed power from both utility and distributed energy resources sources is shown. Courtesy: CDM Smith

How to design standby power systems to withstand storms

Fiberglass Conduit VS PVC Conduit

Edwardsport IGCC Power Plant

How to design data center electrical and power systems

Data Center Process Cooling

Cooling Towers Offer Water and Energy Savings as Part of Efficient Data Center Cooling Systems

## Picking software to model electrical systems

ALWAYS On | ALWAYS Reliable | ALWAYS Mission Critical

Know when, how to specify a rooftop unit

shown in Figure 5. Other configurations such as system in island operation could also be analyzed the same way as discuss here to understand system behavior.

### Codes and standards

The following standards are applicable to performing power system studies such as the load flow, short circuit, protective device coordination, motor starting, harmonic, reliability and arc flash analyses:

- ANSI/IES LP-7-20 Lighting Practice: The Lighting Design and Construction Process.
- ANSI/IES TM-32-19 Technical Memorandum: Lighting Parameters for Building Information Modeling.
- IEEE 519-2014: IEEE Recommended Practice and Requirements for Harmonic Control in Electric Power Systems.
- IEEE 1547-2018: IEEE Standard for Interconnection and Interoperability of Distributed Energy Resources with Associated Electric Power Systems Interfaces.
- IEEE 1584-2018: IEEE Guide for Performing Arc-Flash Hazard Calculations.
- IEEE 2: IEEE Draft Recommended Practice for Conducting Load-Flow Studies of Industrial and Commercial Power Systems.
- IEEE 3: IEEE Draft Recommended Practice for Conducting Short-Circuit Studies of Industrial and Commercial Power Systems.

How to design standby power systems to withstand storms

Fiberglass Conduit VS PVC Conduit

Edwardsport IGCC Power Plant

How to design data center electrical and power systems

Data Center Process Cooling

Cooling Towers Offer Water and Energy Savings as Part of Efficient Data Center Cooling Systems

### Picking software to model electrical systems

ALWAYS On | ALWAYS Reliable | ALWAYS Mission Critical

Know when, how to specify a rooftop unit



- IEEE 7: IEEE Recommended Practice for Conducting Motor-Starting Studies and Analysis of Industrial and Commercial Power Systems.
- IEEE 8: IEEE Draft Recommended Practice for Conducting Harmonic-Analysis Studies of Industrial and Commercial Power Systems.
- NFPA 70: National Electrical Code.

Designing new facilities or making system modifications and improvements without having electrical modeling and analyses can lead to costly failures and jeopardize personnel safety. It is highly recommended to invest and build electrical distribution system models — especially for facilities that are more complex and plan to or already have additional uninterruptible sources such as a microgrid system. This is necessary to understand the facility's capability for safe and reliable operation.

### **Zia Salami and Orlando D. Cruz**

**Zia Salami** is a subject matter expert: electrical power systems at CDM Smith. Salami has served in several roles as an advisory engineer, consultant and academic professor.

**Orlando D. Cruz** is a senior electrical engineer at CDM Smith. Cruz has served as an electrical consultant on power and lighting system projects throughout the world and actively participates in committees that develop lighting design standards.

How to design standby power systems to withstand storms

Fiberglass Conduit VS PVC Conduit

Edwardsport IGCC Power Plant

How to design data center electrical and power systems

Data Center Process Cooling

Cooling Towers Offer Water and Energy Savings as Part of Efficient Data Center Cooling Systems

### **Picking software to model electrical systems**

ALWAYS On | ALWAYS Reliable | ALWAYS Mission Critical

Know when, how to specify a rooftop unit



Engineered to order. Built to last.



**ALWAYS** On | **ALWAYS** Reliable | **ALWAYS** Mission Critical

When it comes to powering mission critical operations, loss of power can be costly. G&W Electric helps ensure reliable performance in the most demanding environments with time tested power solutions. Our engineers focus on creating the most innovative solutions with the utmost reliability.

G&W Electric keeps operations running smoothly with time-tested power solutions.

[LEARN MORE](#)

[gwelectric.com](http://gwelectric.com)



**ALWAYS On  
ALWAYS Reliable  
ALWAYS Mission  
Critical**

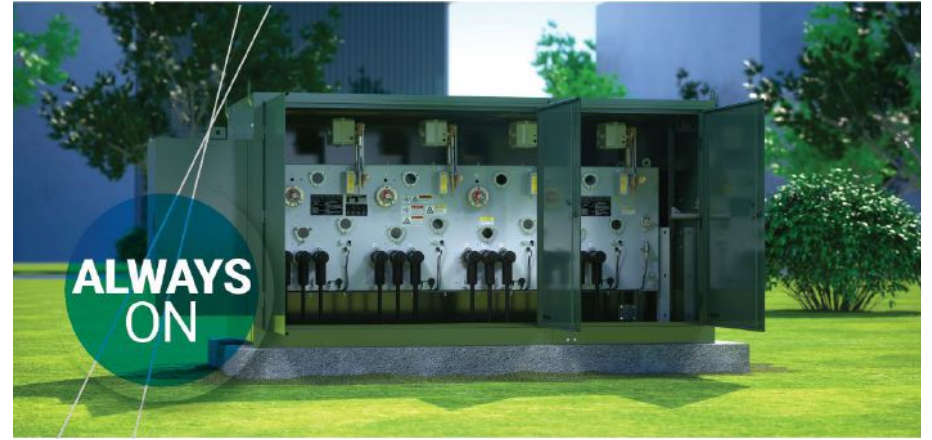

*When it comes to powering mission critical operations, loss of power can be costly. That's why G&W Electric helps ensure reliable performance in the most demanding environments with proven power solutions.*

**W**e deliver power solutions that hit the mark, while reducing costs with easy-to-implement upgrades. Our switchgear is rated up to 38kV, 900 amps continuous and up to 25kA short circuit interruption with little to no maintenance. G&W Electric switchgear delivers enhanced safety with clear indication of the vacuum contacts through the SafeVu viewing window and are fully submersible.



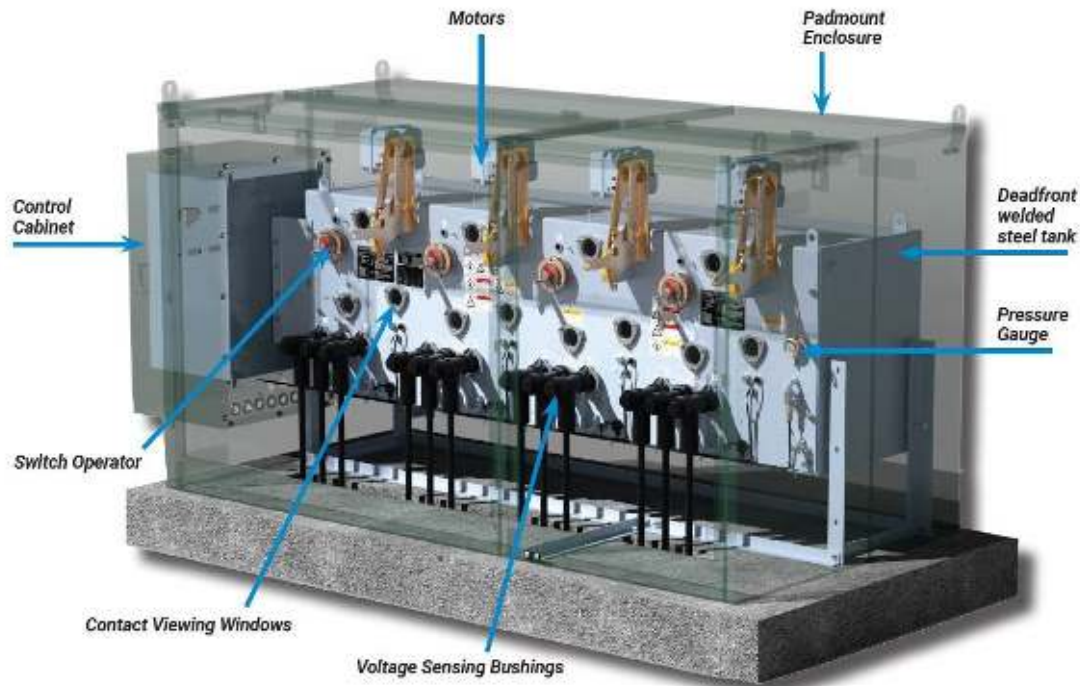

**G&W Electric switchgear is automaton ready and offers:**

- Integral current and voltage sensors on load ways
- Motor operators
- Switch position indication
- Test switches
- Relay agnostic (SEL, GE, ABB etc.)
- Compatible with fiber and/or copper ethernet

How to design standby power systems to withstand storms

Fiberglass Conduit VS PVC Conduit

Edwardsport IGCC Power Plant

How to design data center electrical and power systems

Data Center Process Cooling

Cooling Towers Offer Water and Energy Savings as Part of Efficient Data Center Cooling Systems

Picking software to model electrical systems

**ALWAYS On | ALWAYS Reliable | ALWAYS Mission Critical**

Know when, how to specify a rooftop unit

- Battery backup
- Integral current sensors on source ways provide:
  - Bus fault detection capability
  - FDIR (Fault Detection, Isolation and Restoration) ready solution

**Switch Features:**

- Padmount enclosure with control cabinet mounted in a separate low voltage enclosure for easy access
- Deadfront welded steel tank design
- Viewing windows with clear indication of vacuum contacts
- Pressure gauge and Low Pressure Warning Device for safe operation of switchgear
- Different Configuration Options:
  - Front configuration – shown in the graphic
  - Front/back configuration
  - Front/rear configuration
- Hook stick operable switch operators
- Motor operators allow for remote operation and/or automation of the switchgear
- Integral voltage sensing bushings

How to design standby power systems to withstand storms

Fiberglass Conduit VS PVC Conduit

Edwardsport IGCC Power Plant

How to design data center electrical and power systems

Data Center Process Cooling

Cooling Towers Offer Water and Energy Savings as Part of Efficient Data Center Cooling Systems

Picking software to model electrical systems

**ALWAYS On | ALWAYS Reliable | ALWAYS Mission Critical**

Know when, how to specify a rooftop unit

# Know when, how to specify a rooftop unit

*There are some key components to recognize when designing air-cooled rooftop units*

**R**ooftop units have long been used to satisfy building heating, ventilation and air conditioning requirements. Some of the benefits of rooftop units include lower first cost, ease of installation and reduction of area inside the building for mechanical equipment.

The maintenance of rooftop units also can be a benefit if proper roof access is available. All of the components are in one location to be worked on and maintenance personnel do not have to go throughout a building to find various units such as with a water-source heat pump system.

## **Rooftop unit efficiencies**

Rooftop units are rated for different efficiencies based on the tonnage. Units rated for less than 65,000 Btu/hour are rated to a seasonal energy efficiency ratio, which “measures the total cooling of a central air conditioner or heat pump (in Btu) during the normal cooling season as compared to the total electric energy input (in watt-hours) consumed during the same period.”

Units rated for 65,000 Btu/hour and higher are rated to energy efficiency ratio, which “measures of how efficiently a cooling system will operate when the outdoor temperature is at a specific level.” The energy efficiency ratio value is the efficiency at the peak cooling condition.

How to design standby power systems to withstand storms

Fiberglass Conduit VS PVC Conduit

Edwardsport IGCC Power Plant

How to design data center electrical and power systems

Data Center Process Cooling

Cooling Towers Offer Water and Energy Savings as Part of Efficient Data Center Cooling Systems

Picking software to model electrical systems

ALWAYS On | ALWAYS Reliable | ALWAYS Mission Critical

**Know when, how to specify a rooftop unit**



The integrated energy efficiency ratio is used on the larger tonnage units as a measure of efficiency at part load conditions. Table C403.3.2 in the International Energy Conservation Code outlines the minimum efficiencies required for different types of rooftop units, such as cooling only units or heat pumps and minimum efficiencies required based on the tonnage of the units.

### Derating equipment

There are some general design parameters that apply to both package rooftop units and applied rooftop units. The ambient temperature will affect the performance of air-cooled equipment. All unitary air conditioners and heat pumps are tested and rated to AHRI Standards. AHRI Standard 210/240 is applicable for equipment less than 65,000 Btu/hour and AHRI Standard 340/360 is applicable for equipment from 65,000 Btu/hour to less than 250,000 Btu/hour.



Figure 1: A total enthalpy wheel installed rooftop unit can provide additional energy savings. Courtesy: SmithGroup

How to design standby power systems to withstand storms

Fiberglass Conduit VS PVC Conduit

Edwardsport IGCC Power Plant

How to design data center electrical and power systems

Data Center Process Cooling

Cooling Towers Offer Water and Energy Savings as Part of Efficient Data Center Cooling Systems

Picking software to model electrical systems

ALWAYS On | ALWAYS Reliable | ALWAYS Mission Critical

**Know when, how to specify a rooftop unit**

## Know when, how to specify a rooftop unit

---

The latest version of these standards is 2019 and 2017, respectively, which rate air-cooled equipment at 95°F dry bulb and 75°F wet bulb in the cooling condition, and 47°F dry bulb or 17°F dry bulb in the heating condition. These have long been the ambient temperatures air cooled equipment has been rated at.

These conditions apply to vast parts of the United States, but if a project is located in the Pacific Northwest, Southwest desert or upper Midwest, for example, the design ambient temperatures will be different from the standard testing temperatures.

Rooftop units that are installed in high-temperature locations, such as Phoenix, need to be derated due to ambient dry bulb temperatures that can reach 115°F. The daytime high temperatures can be 115°F with temperatures on a roof being near or exceeding 125°F. The rooftop unit is not able to reject as much heat to the atmosphere when the dry bulb is higher outside, so the total capacity and sensible capacity will be less than what is listed in a manufacturer's catalog.

Many locations in the United States have a design heating temperature lower than 17°F. The building can still have a call for cooling, depending on the building use type. This can cause an issue with head pressure in the condenser and cause the refrigeration system to short cycle or have other problems. Manufacturers offer low ambient controls or kits that will enable the refrigeration system to operate properly at low ambient conditions. These are accessories and need to be specified by the design engineer. Engineers should be cognizant of the design ambient conditions and how they can affect the capacities of package rooftop units.

The entering air temperature is also a key component when designing air-cooled roof-

How to design standby power systems to withstand storms

Fiberglass Conduit VS PVC Conduit

Edwardsport IGCC Power Plant

How to design data center electrical and power systems

Data Center Process Cooling

Cooling Towers Offer Water and Energy Savings as Part of Efficient Data Center Cooling Systems

Picking software to model electrical systems

ALWAYS On | ALWAYS Reliable | ALWAYS Mission Critical

**Know when, how to specify a rooftop unit**

## Know when, how to specify a rooftop unit

---

top units. AHRI Standard 340/360 also defines the entering air temperature as 80°F dry bulb and 67°F wet bulb. This condition can be different depending on what climate a building is located in.

For example, in hot, dry climates a typical entering air temperature could be 78°F dry bulb and 63°F wet bulb. This will reduce the capacities of the rooftop unit from the listed catalog data. Air-cooled rooftop units are commonly used for office buildings and light commercial spaces. These spaces typically are 15% to 20% outside air and the entering dry bulb temperature is below 90°F.

It is important to keep the entering dry bulb temperature below 90°F to this type of equipment so the refrigerant system can operate properly. Most manufacturers rate this type of equipment to 90°F in their catalogs. This is due to not have the refrigeration circuit fail on high head pressure and to limit the compressor from cycling too often.

There is a limit to the temperature difference across the cooling coil that air-cooled equipment can produce because of the refrigeration cycle. These types of units can typically produce a 20°F to 25°F delta T in the cooling condition. An engineer should always calculate the entering air temperature to the equipment and ensure that the equipment will properly condition the space in both the cooling mode and the dehumidification mode. A rooftop unit will not dehumidify to below the standard room condition of 75°F and 50% relative humidity if the entering air temperature is too high. This will cause humidity to build up in the space and become uncomfortable to the occupants.

How to design standby power systems to withstand storms

Fiberglass Conduit VS PVC Conduit

Edwardsport IGCC Power Plant

How to design data center electrical and power systems

Data Center Process Cooling

Cooling Towers Offer Water and Energy Savings as Part of Efficient Data Center Cooling Systems

Picking software to model electrical systems

ALWAYS On | ALWAYS Reliable | ALWAYS Mission Critical

**Know when, how to specify a rooftop unit**



An engineer should look at different duct layouts associated with the rooftop units and shift rooms to adjoining rooftop units to lower the entering air temperature or using specialty package rooftop units if an entering air temperature approaches 90°F dry bulb.



*Figure 2: An applied rooftop unit has multiple coils and airside economizer.  
Courtesy: SmithGroup/Liam Fredrick*

### Equipment improvements

A common problem with air-cooled rooftop equipment is oversizing. Most engineers are conservative in nature and want to ensure that there is enough cooling and heating capacity. Engineers dread the phone call saying the space is too hot or too cold or that the controls aren't working properly or that there are operations and maintenance issues. This can lead to several issues with package rooftop equipment.

Calculated peak load will occur for a few hours during the year, depending on which design criteria the engineer selects for a building. Typically, the 0.4% or 1% weather values are used from the ASHRAE weather data tables. That means the air conditioning equipment will need to operate at a reduced load 99% of the year.

How to design standby power systems to withstand storms

Fiberglass Conduit VS PVC Conduit

Edwardsport IGCC Power Plant

How to design data center electrical and power systems

Data Center Process Cooling

Cooling Towers Offer Water and Energy Savings as Part of Efficient Data Center Cooling Systems

Picking software to model electrical systems

ALWAYS On | ALWAYS Reliable | ALWAYS Mission Critical

**Know when, how to specify a rooftop unit**

**Table 1: Calculations based on entering air temperature**

Condition/ location	TEMPERATURE			GROSS CAPACITY		Elevation (feet)
	Ambient (°F)	EAT* dry bulb (°F)	EAT wet bulb (°F)	Total Btu/hour	Sensible Btu/hour	
<b>Cooling at AHRI standard EAT</b>						
San Francisco	82	80	67	135,960	100,203	0
AHRI	95	80	67	124,000	93,000	0
Phoenix	115	80	67	104,100	84,321	1,200
<b>Cooling at design EAT</b>						
San Francisco	82	78	61	123,000	116,210	0
AHRI	95	83	63	116,400	114,538	0
Phoenix	115	83	63	98,000	98,000	1,200
<b>Heating at AHRI standard EAT</b>						
Detroit	5	70	60	55,900	N/A	0
AHRI	17	70	60	72,000	N/A	0
Seattle	25	70	60	79,400	N/A	0

\* Entering air temperature

Manufacturers, in response to stricter code requirements, have been able to improve the part-load operation of this equipment in recent years. Some of these improvements include variable speed compressors, electronically commutated motors and microchannel heat exchangers.

Equipment improvements allow air-cooled equipment to operate at part load much better than they have in the past and reduce energy consumption. These items replace single stage compressors and belt-driven fans that have long been used in package rooftop equipment, which had very limited turndown capabilities. These improvements help avoid the empty movie theater syndrome where the rooftop unit is at its minimum operating point, but there is no load in the space and people have jackets on in the middle of the summer.

Table 1: This data is based on a 10-ton air-cooled heat pump package rooftop unit.

Courtesy: SmithGroup

How to design standby power systems to withstand storms

Fiberglass Conduit VS PVC Conduit

Edwardsport IGCC Power Plant

How to design data center electrical and power systems

Data Center Process Cooling

Cooling Towers Offer Water and Energy Savings as Part of Efficient Data Center Cooling Systems

Picking software to model electrical systems

ALWAYS On | ALWAYS Reliable | ALWAYS Mission Critical

**Know when, how to specify a rooftop unit**

### Smoke control equipment

A potential issue when multiple package rooftop units are used with a common return plenum is whether smoke detectors are required. Section 606.2 of the International Mechanical Code requires smoke detectors on all units with a return airflow of 2,000 cubic feet per minute or greater. This would require smoke detectors on package rooftop equipment that are smaller than 5 tons.



Figure 3: An air-cooled package rooftop unit shows lab exhaust stacks in the background. Courtesy: SmithGroup

### Acoustical considerations

It is important to properly design the acoustics for any HVAC system. There are two key components when working with HVAC acoustics and those are sound power and sound pressure. Sound power is the acoustical energy emitted by a source (i.e., a rooftop unit) and is a fixed value. Sound pressure is the level of the noise produced by the source. The sound pressure level can vary depending on how far away from the source and what acoustical treatments are between the source and the measurement point.

Where rooftop units are located is important when considering the acoustical impact these types of units can have on an occupied space. Chapter 49 of the 2019 ASHRAE

How to design standby power systems to withstand storms

Fiberglass Conduit VS PVC Conduit

Edwardsport IGCC Power Plant

How to design data center electrical and power systems

Data Center Process Cooling

Cooling Towers Offer Water and Energy Savings as Part of Efficient Data Center Cooling Systems

Picking software to model electrical systems

ALWAYS On | ALWAYS Reliable | ALWAYS Mission Critical

**Know when, how to specify a rooftop unit**



## Know when, how to specify a rooftop unit

---

HVAC Applications Handbook states the appropriate noise criterion level that spaces should be designed to be based on the use. It is always best to locate rooftop units over spaces with a higher NC level, such as storage rooms or corridors that have a 40 NC level instead of noise-sensitive spaces such as conference rooms, which have a 30 NC level. Additional design considerations are required when units are located over sound-sensitive spaces or the unit will create more noise than acceptable for the space below.

There are different pathways that have to be considered when dealing with the acoustics of rooftop units:

- Airborne sound is the sound that travels down the ductwork.
- Breakout sound passes through the walls of the ductwork.
- Radiated sound is transmitted through the cabinet of the unit.

Acoustical treatments can be necessary to meet the required NC levels of the various spaces in a building. Typically, acoustical treatments are needed in the lower octave bands of 63, 125 and 250 hertz. These octave bands produce the low rumble sound from a mechanical unit. The other octave bands — 500, 1,000, 2,000, 4,000 and 8,000 hertz — are mid and high frequencies that produce the high-pitched sounds. Depending on the space requirements, the mid and high frequencies may not require as many acoustical treatments as the low frequencies.

Acoustical sounds treatments are usually required when the rooftop units have lower

How to design standby power systems to withstand storms

Fiberglass Conduit VS PVC Conduit

Edwardsport IGCC Power Plant

How to design data center electrical and power systems

Data Center Process Cooling

Cooling Towers Offer Water and Energy Savings as Part of Efficient Data Center Cooling Systems

Picking software to model electrical systems

ALWAYS On | ALWAYS Reliable | ALWAYS Mission Critical

**Know when, how to specify a rooftop unit**

octave band ratings in the 80-decibel range. Larger rooftop units, such as 50-ton and larger units, will often have decibel ratings of 90 decibels or higher in the lower octave bands.

There are several ways accommodate these frequencies when designing HVAC systems. More distance from a unit's supply and return opening before entering the space or a duct takeoff will allow for more sound reduction in the ductwork. Using horizontal supply and return ductwork connections to rooftop units will allow additional straight ductwork and elbows to be installed when compared to using vertical supply and return ductwork connections to rooftop units. This also allows for duct liner to be used, which can reduce sound levels in most duct configurations.

Additional ductwork elbows help reduce the sound levels by reflecting the sound wave. An engineer must balance sound performance with the pressure drop and fan performance with the type of ductwork elbows used. A smooth radius elbow will have different attenuation levels than a mitered elbow with turning vanes.

Another option to reduce sound levels is the use of sound attenuators that replace a section of ductwork. These come in rectangular, circular, T-shape or elbow configurations. There are several options for sound attenuators from the internal baffle type and length. Because the airflow is being restricted through a sound attenuator, there is a static pressure drop that an engineer needs to account for. The pressure drop is based on the velocity so the static pressure drop can vary greatly.

For example, a static pressure loss could be 0.10 inch for a sound attenuator design for a duct velocity of 500 fpm compared to a static pressure drop of 1 inch or more for

How to design standby power systems to withstand storms

Fiberglass Conduit VS PVC Conduit

Edwardsport IGCC Power Plant

How to design data center electrical and power systems

Data Center Process Cooling

Cooling Towers Offer Water and Energy Savings as Part of Efficient Data Center Cooling Systems

Picking software to model electrical systems

ALWAYS On | ALWAYS Reliable | ALWAYS Mission Critical

**Know when, how to specify a rooftop unit**

a duct velocity of 2,000 fpm or greater. Good engineering practice is to design the systems for a static pressure of 0.25 inches or less. This can be done through a combination of increasing duct velocity and selecting the appropriate type of sound attenuator.

It is important to also analyze the return air ductwork path for airborne sound transmission, as sound from the rooftop unit will travel back through the return duct and into the space. All of the airborne treatments mentioned above also need to be considered for the return air path from a rooftop unit. The return path can lead to noise issues in the space if the return ductwork has a direct path to the occupied space.

Supply ductwork breakout noise is often the critical path when dealing with rooftop unit sound levels. Some of these items can help with this such as duct elbows and duct liner. The ceiling type has a significant impact in reducing this sound path.



*Figure 4: A vibration curb is used to isolate a rooftop unit from transmitting sound and vibrations to the building structure.  
Courtesy: SmithGroup*

How to design standby power systems to withstand storms

Fiberglass Conduit VS PVC Conduit

Edwardsport IGCC Power Plant

How to design data center electrical and power systems

Data Center Process Cooling

Cooling Towers Offer Water and Energy Savings as Part of Efficient Data Center Cooling Systems

Picking software to model electrical systems

ALWAYS On | ALWAYS Reliable | ALWAYS Mission Critical

**Know when, how to specify a rooftop unit**



## Know when, how to specify a rooftop unit

---

It is important to work with the architect when determining ductwork breakout noise levels. A ceiling with a higher sound performance can reduce or eliminate some of the HVAC sound mitigation requirements. Ceilings are rated for a noise reduction coefficient value. The ceiling materials are rated in the 250, 500, 1,000 and 2,000 hertz octave band in accordance with ASTM C423. The noise reduction coefficient value ranges from 0 to 1 with the higher the number meaning the more acoustic adsorption the ceiling provides.

Conference room ceilings are typically rated for a 0.9 noise reduction coefficient value. Duct lagging is a flexible mass-produced product that can be used to reduce the effects of ductwork breakout noise. While it is a high-end, expensive solution, it may be appropriate in some applications. Lagging is applied around the outside of the ductwork and typically is available in 1 pound per cubic foot densities.

Radiated sound from rooftop units can cause issues for the spaces underneath where the rooftop units are located. This is becoming more critical as open ceiling concepts have become more popular, as well as if the unit is located over sound-sensitive spaces such as conference rooms or private offices. The ceiling has a large effect on radiated sound. Without a ceiling, the sound mitigation becomes critical.

A mass form is often needed in and/or around the rooftop unit to mitigate the sound transmission from the rooftop unit through the roof. This is mostly dealing with the lower octave bands noted above. There are options on how this achieved and varies from building to building. A common solution is to provide additional concrete at the rooftop unit. This can cause issues with the roof structure, so this needs to be coordinated with the structural engineer.

How to design standby power systems to withstand storms

Fiberglass Conduit VS PVC Conduit

Edwardsport IGCC Power Plant

How to design data center electrical and power systems

Data Center Process Cooling

Cooling Towers Offer Water and Energy Savings as Part of Efficient Data Center Cooling Systems

Picking software to model electrical systems

ALWAYS On | ALWAYS Reliable | ALWAYS Mission Critical

**Know when, how to specify a rooftop unit**

An alternate solution to this is to provide a hollow concrete curb and use acoustical material to infill the curb. This can provide similar acoustical performance to a solid concrete mass as described above and significantly reduce the weight the roof structure must be designed for.

Rooftop units have rotating parts like all other mechanical equipment that produce vibrations. These include the supply fans, exhaust fans, condenser fans and compressors. It is critical to deal with these so the vibrations are not transmitted to the building structure. Several manufacturers internally isolate these parts, but additional means might be necessary. Vibration curbs isolate the entire rooftop unit through a series of spring isolators located around the curb. It is important to coordinate this with the rooftop unit manufacturer so spring isolators are not doubled up. This can lead to a resonance issue, which can be worse than not providing any vibration isolation.

### **Applied rooftop units**

Although the available options between package rooftop units and applied rooftop units are getting less and less, there are still differences. Package rooftop units are limited in the components that are available. These include supply fan, exhaust fan, direct expansion cooling coil and a gas-fired or electric heating coil. These components are sufficient for a lot of building types, though not all.

An applied air-cooled rooftop unit maybe required, depending on the design requirements such as a low entering air temperature that would require a preheat coil. Additional components are available in applied air-cooled rooftop units as manufacturers make improvements that are used in a host of air handling units. These include return

How to design standby power systems to withstand storms

Fiberglass Conduit VS PVC Conduit

Edwardsport IGCC Power Plant

How to design data center electrical and power systems

Data Center Process Cooling

Cooling Towers Offer Water and Energy Savings as Part of Efficient Data Center Cooling Systems

Picking software to model electrical systems

ALWAYS On | ALWAYS Reliable | ALWAYS Mission Critical

**Know when, how to specify a rooftop unit**

## Know when, how to specify a rooftop unit

---

fans, chilled water-cooling coils, steam heating coils, energy recovery wheels, additional filtration levels and fan arrays. Return fans might be desired instead of the typical relief or exhaust fan that is only offered in package rooftop units.

Energy recovery systems are available in 30-ton units and larger, depending on the manufacturer. Applied rooftop units have a higher first cost, so it is important to know what the requirements are so there are no surprises with the project budget.

### **Jon Silhol**

***Jon Silhol** is a mechanical engineer with SmithGroup. He is a member of ASHRAE and has 20 years of experience designing mechanical systems for various building types.*

How to design standby power systems to withstand storms

Fiberglass Conduit VS PVC Conduit

Edwardsport IGCC Power Plant

How to design data center electrical and power systems

Data Center Process Cooling

Cooling Towers Offer Water and Energy Savings as Part of Efficient Data Center Cooling Systems

Picking software to model electrical systems

ALWAYS On | ALWAYS Reliable | ALWAYS Mission Critical

**Know when, how to specify a rooftop unit**



# Data Centers

---

## Content Archive

2021 Spring Edition

2021 Winter Edition

2020 Fall Edition

2020 Summer Edition

Thank you for visiting the Data Centers eBook!

If you have any questions or feedback about the contents in this eBook, please contact CFE Media at [\*customerservice@cfemedia.com\*](mailto:customerservice@cfemedia.com)

We would love to hear from you!

