

# Fittings

## BOX CONNECTOR

(Straight Threads)

	NOMINAL		XW ITEM NO		D		L		WEIGHT	
	SIZE	TYPE	BELOW GROUND	ABOVE GROUND					LBS	KG
<input type="checkbox"/>	3/4"	XW	07A-XW-30	07C-XW-30	1.435"	(36)	3"	(76)	0.11	(0.05)
<input type="checkbox"/>	1"	XW	10A-XW-30	10C-XW-30	1.700"	(43)	3"	(76)	0.22	(0.10)
<input type="checkbox"/>	1-1/4"	XW	12A-XW-30	12C-XW-30	2.045"	(52)	3"	(76)	0.35	(0.16)
<input type="checkbox"/>	1-1/2"	XW	15A-XW-30	15C-XW-30	2.285"	(58)	3"	(76)	0.49	(0.22)
<input type="checkbox"/>	2"	XW	20B-XW-30	20D-XW-30	2.520"	(64)	5"	(127)	0.85	(0.39)
<input type="checkbox"/>	2-1/2"	XW	25B-XW-30	25D-XW-30	3.025"	(77)	5"	(127)	0.94	(0.43)
<input type="checkbox"/>	3"	XW	30B-XW-30	30D-XW-30	3.520"	(89)	5"	(127)	1.28	(0.58)
<input type="checkbox"/>	3-1/2"	XW	35B-XW-30	35D-XW-30	4.025"	(102)	5"	(127)	1.77	(0.80)
<input type="checkbox"/>	4"	XW	40B-XW-30	40D-XW-30	4.520"	(115)	7"	(178)	2.09	(0.95)
<input type="checkbox"/>	5"	XW	50B-XW-30	50D-XW-30	5.520"	(140)	7"	(178)	2.75	(1.25)
<input type="checkbox"/>	6"	XW	60B-XW-30	60D-XW-30	6.520"	(166)	7"	(178)	2.97	(1.35)
<input type="checkbox"/>	8"	XW	80A-XW-30	80C-XW-30	8.920"	(227)	8"	(203)	5.24	(2.37)

A box connector creates a separable termination into a box. This connector has straight threads (NPT) and is supplied with a locknut. Sealing O-ring supplied by adding an "-EX" suffix to the item number.

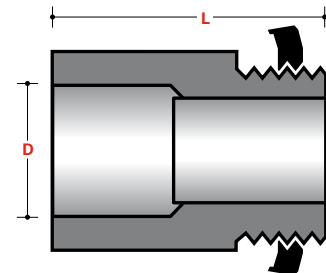

## MALE ADAPTER

(Straight Threads)

	NOMINAL		XW ITEM NO		D		L		WEIGHT	
	SIZE	TYPE	BELOW GROUND	ABOVE GROUND					LBS	KG
<input type="checkbox"/>	3/4"	XW	07A-XW-33	07C-XW-33	1.435"	(36)	3"	(76)	0.09	(0.04)
<input type="checkbox"/>	1"	XW	10A-XW-33	10C-XW-33	1.700"	(43)	3"	(76)	0.19	(0.09)
<input type="checkbox"/>	1-1/4"	XW	12A-XW-33	12C-XW-33	2.045"	(52)	3"	(76)	0.24	(0.11)
<input type="checkbox"/>	1-1/2"	XW	15A-XW-33	15C-XW-33	2.285"	(58)	3"	(76)	0.35	(0.16)
<input type="checkbox"/>	2"	XW	20B-XW-33	20D-XW-33	2.520"	(64)	5"	(127)	0.69	(0.31)
<input type="checkbox"/>	2-1/2"	XW	25B-XW-33	25D-XW-33	3.025"	(77)	5"	(127)	0.85	(0.38)
<input type="checkbox"/>	3"	XW	30B-XW-33	30D-XW-33	3.520"	(89)	5"	(127)	1.00	(0.45)
<input type="checkbox"/>	3-1/2"	XW	35B-XW-33	35D-XW-33	4.025"	(102)	5"	(127)	1.28	(0.58)
<input type="checkbox"/>	4"	XW	40B-XW-33	40D-XW-33	4.520"	(115)	7"	(178)	1.56	(0.71)
<input type="checkbox"/>	5"	XW	50B-XW-33	50D-XW-33	5.520"	(140)	7"	(178)	2.08	(0.94)
<input type="checkbox"/>	6"	XW	60B-XW-33	60D-XW-33	6.520"	(166)	7"	(178)	2.47	(1.12)
<input type="checkbox"/>	8"	XW	80A-XW-33	80C-XW-33	8.920"	(227)	8"	(203)	5.29	(2.37)

Male adapters with straight threads (NPT) are generally used for joining to female threads of rigid steel, Myers-type hubs or terminating into precast iron boxes with female thread entrances.

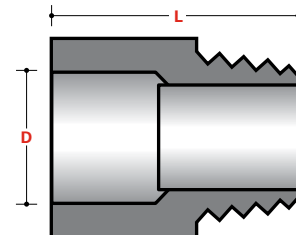

## SPECIAL ADAPTER FOR PVC-COATED FITTINGS

(Male Adapter)

	NOMINAL		XW ITEM NO		D		L		L1		WEIGHT	
	SIZE	TYPE	BELOW GROUND	ABOVE GROUND							LBS	KG
<input type="checkbox"/>	3/4"	XW	07A-XW-24	07C-XW-24	1.435"	(36)	3.75"	(95)	0.75"	(18)	0.36	(0.16)
<input type="checkbox"/>	1"	XW	10A-XW-24	10C-XW-24	1.700"	(43)	4.00"	(102)	1.00"	(25)	0.50	(0.23)
<input type="checkbox"/>	1-1/4"	XW	12A-XW-24	12C-XW-24	2.045"	(52)	4.25"	(108)	1.25"	(32)	0.60	(0.27)
<input type="checkbox"/>	1-1/2"	XW	15A-XW-24	15C-XW-24	2.285"	(58)	4.50"	(114)	1.50"	(38)	0.90	(0.41)
<input type="checkbox"/>	2"	XW	20B-XW-24	20D-XW-24	2.520"	(64)	7.00"	(178)	2.00"	(51)	0.69	(0.31)
<input type="checkbox"/>	2-1/2"	XW	25B-XW-24	25D-XW-24	3.025"	(77)	7.00"	(178)	2.00"	(51)	1.20	(0.45)
<input type="checkbox"/>	3"	XW	30B-XW-24	30D-XW-24	3.520"	(89)	7.00"	(178)	2.00"	(51)	1.00	(0.45)
<input type="checkbox"/>	3-1/2"	XW	35B-XW-24	35D-XW-24	4.025"	(102)	7.00"	(178)	2.00"	(51)	1.20	(0.54)
<input type="checkbox"/>	4"	XW	40B-XW-24	40D-XW-24	4.520"	(115)	7.00"	(178)	2.00"	(51)	1.56	(0.71)
<input type="checkbox"/>	5"	XW	50B-XW-24	50D-XW-24	5.520"	(140)	7.00"	(178)	2.00"	(51)	2.08	(0.94)
<input type="checkbox"/>	6"	XW	60B-XW-24	60D-XW-24	6.520"	(166)	7.00"	(178)	2.00"	(51)	2.47	(1.12)

This terminal adapter has tapered threads and a straight shoulder so it can fit under the PVC sleeve of a PVC-coated steel fitting.

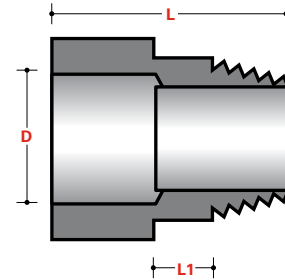

## FEMALE ADAPTER

	NOMINAL		XW ITEM NO		D		L		WEIGHT	
	SIZE	TYPE	BELOW GROUND	ABOVE GROUND						
<input type="checkbox"/>	3/4"	XW	07A-XW-32	07C-XW-32	1.435"	(36)	3"	(76)	0.30	(0.14)
<input type="checkbox"/>	1"	XW	10A-XW-32	10C-XW-32	1.700"	(43)	3"	(76)	0.38	(0.17)
<input type="checkbox"/>	1-1/4"	XW	12A-XW-32	12C-XW-32	2.045"	(52)	3"	(76)	0.45	(0.20)
<input type="checkbox"/>	1-1/2"	XW	15A-XW-32	15C-XW-32	2.285"	(58)	3"	(76)	0.60	(0.27)
<input type="checkbox"/>	2"	XW	20B-XW-32	20D-XW-32	2.520"	(64)	5"	(127)	1.20	(0.55)
<input type="checkbox"/>	2-1/2"	XW	25B-XW-32	25D-XW-32	3.025"	(77)	5"	(127)	0.85	(0.38)
<input type="checkbox"/>	3"	XW	30B-XW-32	30D-XW-32	3.520"	(89)	5"	(127)	1.40	(0.64)
<input type="checkbox"/>	3-1/2"	XW	35B-XW-32	35D-XW-32	4.025"	(102)	5"	(127)	1.28	(0.58)
<input type="checkbox"/>	4"	XW	40B-XW-32	40D-XW-32	4.520"	(115)	7"	(178)	2.08	(0.94)
<input type="checkbox"/>	5"	XW	50B-XW-32	50D-XW-32	5.520"	(140)	7"	(178)	2.60	(1.18)
<input type="checkbox"/>	6"	XW	60B-XW-32	60D-XW-32	6.520"	(166)	7"	(178)	3.51	(1.59)

This adapter is generally used for joining fiberglass conduit with galvanized rigid steel (GRS) conduit. It has the same threads as GRS conduit and can easily be attached to GRS conduit.

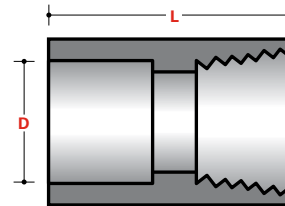

## SLEEVE COUPLING

	NOMINAL		XW ITEM NO		D	L	WEIGHT	
	SIZE	TYPE	BELOW GROUND	ABOVE GROUND			LBS	KG
<input type="checkbox"/>	3/4"	XW	07A-XW-42	07C-XW-42	1.435" (36)	6" (152)	0.22	(0.10)
<input type="checkbox"/>	1"	XW	10A-XW-42	10C-XW-42	1.700" (43)	6" (152)	0.29	(0.13)
<input type="checkbox"/>	1-1/4"	XW	12A-XW-42	12C-XW-42	2.045" (52)	6" (152)	0.36	(0.16)
<input type="checkbox"/>	1-1/2"	XW	15A-XW-42	15C-XW-42	2.285" (58)	6" (152)	0.39	(0.18)
<input type="checkbox"/>	2"	XW	20B-XW-42	20D-XW-42	2.520" (64)	10" (254)	0.88	(0.40)
<input type="checkbox"/>	2-1/2"	XW	25B-XW-42	25D-XW-42	3.025" (77)	10" (254)	1.08	(0.49)
<input type="checkbox"/>	3"	XW	30B-XW-42	30D-XW-42	3.520" (89)	10" (254)	1.25	(0.57)
<input type="checkbox"/>	3-1/2"	XW	35B-XW-42	35D-XW-42	4.025" (102)	10" (254)	1.87	(0.85)
<input type="checkbox"/>	4"	XW	40B-XW-42	40D-XW-42	4.520" (115)	10" (254)	1.50	(0.68)
<input type="checkbox"/>	5"	XW	50B-XW-42	50D-XW-42	5.520" (140)	10" (254)	2.08	(0.94)
<input type="checkbox"/>	6"	XW	60B-XW-42	60D-XW-42	6.520" (166)	10" (254)	2.50	(1.13)
<input type="checkbox"/>	8"	XW	80A-XW-42	80C-XW-42	8.920" (227)	10" (254)	3.00	(1.36)

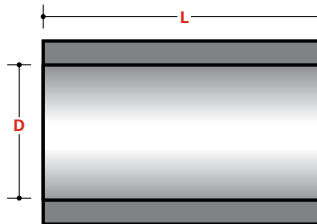

## STOP COUPLING

	NOMINAL		XW ITEM NO		D	L	WEIGHT	
	SIZE	TYPE	BELOW GROUND	ABOVE GROUND			LBS	KG
<input type="checkbox"/>	3/4"	XW	07A-XW-40	07C-XW-40	1.435" (36)	6" (152)	0.22	(0.10)
<input type="checkbox"/>	1"	XW	10A-XW-40	10C-XW-40	1.700" (43)	6" (152)	0.29	(0.13)
<input type="checkbox"/>	1-1/4"	XW	12A-XW-40	12C-XW-40	2.045" (52)	6" (152)	0.36	(0.16)
<input type="checkbox"/>	1-1/2"	XW	15A-XW-40	15C-XW-40	2.285" (58)	6" (152)	0.39	(0.18)
<input type="checkbox"/>	2"	XW	20B-XW-40	20D-XW-40	2.520" (64)	10" (254)	0.88	(0.40)
<input type="checkbox"/>	2-1/2"	XW	25B-XW-40	25D-XW-40	3.025" (77)	10" (254)	1.08	(0.49)
<input type="checkbox"/>	3"	XW	30B-XW-40	30D-XW-40	3.520" (89)	10" (254)	1.25	(0.57)
<input type="checkbox"/>	3-1/2"	XW	35B-XW-40	35D-XW-40	4.025" (102)	10" (254)	1.87	(0.85)
<input type="checkbox"/>	4"	XW	40B-XW-40	40D-XW-40	4.520" (115)	10" (254)	2.00	(0.91)
<input type="checkbox"/>	5"	XW	50B-XW-40	50D-XW-40	5.520" (140)	10" (254)	2.50	(1.13)
<input type="checkbox"/>	6"	XW	60B-XW-40	60D-XW-40	6.520" (166)	10" (254)	2.90	(1.32)
<input type="checkbox"/>	8"	XW	80A-XW-40	80C-XW-40	8.920" (227)	10" (254)	3.00	(1.36)

A stop coupling is sometimes referred to as a double bell coupling.

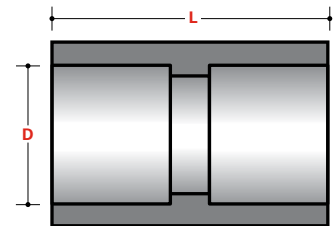

## 5° DOUBLE BELL COUPLING

	NOMINAL		XW ITEM NO		D	L	WEIGHT	
	SIZE	TYPE	BELOW GROUND	ABOVE GROUND			LBS	KG
<input type="checkbox"/>	3/4"	XW	07A-XW-44	07C-XW-44	1.435" (36)	6" (152)	0.22	(0.10)
<input type="checkbox"/>	1"	XW	10A-XW-44	10C-XW-44	1.700" (43)	6" (152)	0.29	(0.13)
<input type="checkbox"/>	1-1/4"	XW	12A-XW-44	12C-XW-44	2.045" (52)	6" (152)	0.36	(0.16)
<input type="checkbox"/>	1-1/2"	XW	15A-XW-44	15C-XW-44	2.285" (58)	6" (152)	0.39	(0.18)
<input type="checkbox"/>	2"	XW	20B-XW-44	20D-XW-44	2.520" (64)	10" (254)	0.92	(0.42)
<input type="checkbox"/>	2-1/2"	XW	25B-XW-44	25D-XW-44	3.025" (77)	10" (254)	1.28	(0.58)
<input type="checkbox"/>	3"	XW	30B-XW-44	30D-XW-44	3.520" (89)	10" (254)	1.48	(0.67)
<input type="checkbox"/>	3-1/2"	XW	35B-XW-44	35D-XW-44	4.025" (102)	10" (254)	1.70	(0.77)
<input type="checkbox"/>	4"	XW	40B-XW-44	40D-XW-44	4.520" (115)	10" (254)	1.53	(0.67)
<input type="checkbox"/>	5"	XW	50B-XW-44	50D-XW-44	5.520" (140)	10" (254)	2.17	(0.98)
<input type="checkbox"/>	6"	XW	60B-XW-44	60D-XW-44	6.520" (166)	10" (254)	2.55	(1.16)

Other angles can also be manufactured, such as 2.5° etc. Please contact Champion Fiberglass for consultation.

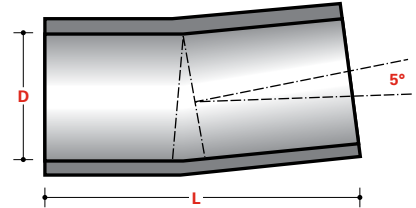

# expansion joints

**Installation of Expansion Joints:**

- When the duct is shorter than 50 ft, no Expansion Joint needed.
- When the duct is between 50 ft up to 200 ft, install one Expansion Joint at the mid point.
- If the duct is longer than 200 ft, install one Expansion Joint every 200 ft apart.
- Expansion Joints should be located as close as possible to the quarter point of the conduit span.

Note: All Expansion Joints have a yellow line on the nipple end of the joint for proper installation.

## SINGLE EXPANSION JOINT SOCKET X SPIGOT, NO O-RING

	NOMINAL		XW ITEM NO ABOVE GROUND	A	B	L - MIN	L - MAX	WEIGHT	
	SIZE	TYPE						LBS	KG
<input type="checkbox"/>	3/4"	XW	07C-XW-34	1.935" (54)	12" (305)	16.5" (419)	24.5" (622)	1.40	(0.64)
<input type="checkbox"/>	1"	XW	10C-XW-34	2.200" (61)	12" (305)	16.5" (419)	24.5" (622)	1.57	(0.71)
<input type="checkbox"/>	1-1/4"	XW	12C-XW-34	2.545" (65)	12" (305)	16.5" (419)	24.5" (622)	1.89	(0.86)
<input type="checkbox"/>	1-1/2"	XW	15C-XW-34	2.785" (71)	12" (305)	16.5" (419)	24.5" (622)	2.72	(1.23)
<input type="checkbox"/>	2"	XW	20D-XW-34	3.000" (76)	12" (305)	20.5" (520)	28.5" (724)	2.90	(1.32)
<input type="checkbox"/>	2-1/2"	XW	25D-XW-34	3.525" (90)	12" (305)	20.5" (520)	28.5" (724)	3.56	(1.61)
<input type="checkbox"/>	3"	XW	30D-XW-34	4.000" (102)	12" (305)	20.5" (520)	28.5" (724)	4.19	(1.90)
<input type="checkbox"/>	3-1/2"	XW	35D-XW-34	4.525" (115)	12" (305)	20.5" (520)	28.5" (724)	4.83	(2.19)
<input type="checkbox"/>	4"	XW	40D-XW-34	5.000" (127)	14" (356)	20.5" (520)	28.5" (724)	6.42	(2.92)
<input type="checkbox"/>	5"	XW	50D-XW-34	6.000" (152)	14" (356)	20.5" (520)	28.5" (724)	7.94	(3.60)
<input type="checkbox"/>	6"	XW	60D-XW-34	7.000" (178)	14" (356)	20.5" (520)	28.5" (724)	10.06	(4.57)
<input type="checkbox"/>	8"	XW	80C-XW-34	9.420" (239)	14" (356)	20.5" (520)	28.5" (724)	13.80	(6.27)

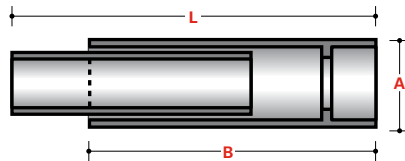

## SINGLE EXPANSION JOINT SOCKET X SPIGOT WITH O-RING

	NOMINAL		XW ITEM NO ABOVE GROUND	A		B		L - MIN		L - MAX		WEIGHT	
	SIZE	TYPE									LBS	KG	
<input type="checkbox"/>	3/4"	XW	07C-XW-36	1.935"	(54)	12"	(305)	16.5"	(419)	24.5"	(622)	1.40	(0.64)
<input type="checkbox"/>	1"	XW	10C-XW-36	2.200"	(61)	12"	(305)	16.5"	(419)	24.5"	(622)	1.57	(0.71)
<input type="checkbox"/>	1-1/4"	XW	12C-XW-36	2.545"	(65)	12"	(305)	16.5"	(419)	24.5"	(622)	1.89	(0.86)
<input type="checkbox"/>	1-1/2"	XW	15C-XW-36	2.785"	(71)	12"	(305)	16.5"	(419)	24.5"	(622)	2.72	(1.23)
<input type="checkbox"/>	2"	XW	20D-XW-36	3.000"	(76)	12"	(305)	20.5"	(520)	28.5"	(724)	2.90	(1.32)
<input type="checkbox"/>	2-1/2"	XW	25D-XW-36	3.525"	(90)	12"	(305)	20.5"	(520)	28.5"	(724)	3.56	(1.61)
<input type="checkbox"/>	3"	XW	30D-XW-36	4.000"	(102)	12"	(305)	20.5"	(520)	28.5"	(724)	4.19	(1.90)
<input type="checkbox"/>	3-1/2"	XW	35D-XW-36	4.525"	(115)	12"	(305)	20.5"	(520)	28.5"	(724)	4.83	(2.19)
<input type="checkbox"/>	4"	XW	40D-XW-36	5.000"	(127)	14"	(356)	20.5"	(520)	28.5"	(724)	6.42	(2.92)
<input type="checkbox"/>	5"	XW	50D-XW-36	6.000"	(152)	14"	(356)	20.5"	(520)	28.5"	(724)	7.94	(3.60)
<input type="checkbox"/>	6"	XW	60D-XW-36	7.000"	(178)	14"	(356)	20.5"	(520)	28.5"	(724)	10.06	(4.57)
<input type="checkbox"/>	8"	XW	80C-XW-36	8.000"	(203)	14"	(356)	20.5"	(520)	28.5"	(724)	12.75	(5.78)

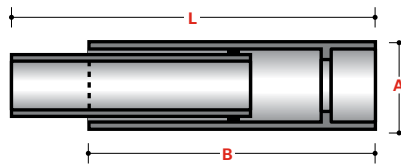

## SINGLE EXPANSION JOINT SOCKET X SOCKET, NO O-RING

	NOMINAL		XW ITEM NO ABOVE GROUND	A		B		L - MIN		L - MAX		WEIGHT	
	SIZE	TYPE									LBS	KG	
<input type="checkbox"/>	3/4"	XW	07C-XW-35	1.935"	(54)	12"	(305)	16.5"	(419)	24.5"	(622)	1.76	(0.80)
<input type="checkbox"/>	1"	XW	10C-XW-35	2.200"	(61)	12"	(305)	16.5"	(419)	24.5"	(622)	1.97	(0.89)
<input type="checkbox"/>	1-1/4"	XW	12C-XW-35	2.545"	(65)	12"	(305)	16.5"	(419)	24.5"	(622)	2.35	(1.07)
<input type="checkbox"/>	1-1/2"	XW	15C-XW-35	2.785"	(71)	12"	(305)	16.5"	(419)	24.5"	(622)	2.72	(1.23)
<input type="checkbox"/>	2"	XW	20D-XW-35	3.000"	(76)	12"	(305)	20.5"	(520)	28.5"	(724)	3.62	(1.64)
<input type="checkbox"/>	2-1/2"	XW	25D-XW-35	3.525"	(90)	12"	(305)	20.5"	(520)	28.5"	(724)	4.44	(2.01)
<input type="checkbox"/>	3"	XW	30D-XW-35	4.000"	(102)	12"	(305)	20.5"	(520)	28.5"	(724)	5.23	(2.37)
<input type="checkbox"/>	3-1/2"	XW	35D-XW-35	4.525"	(115)	12"	(305)	20.5"	(520)	28.5"	(724)	6.06	(2.75)
<input type="checkbox"/>	4"	XW	40D-XW-35	5.000"	(127)	14"	(356)	20.5"	(520)	28.5"	(724)	7.89	(3.58)
<input type="checkbox"/>	5"	XW	50D-XW-35	6.000"	(152)	14"	(356)	20.5"	(520)	28.5"	(724)	9.75	(4.43)
<input type="checkbox"/>	6"	XW	60D-XW-35	7.000"	(178)	14"	(356)	20.5"	(520)	28.5"	(724)	12.08	(5.48)
<input type="checkbox"/>	8"	XW	80C-XW-35	8.000"	(203)	14"	(356)	20.5"	(520)	28.5"	(724)	15.10	(6.95)

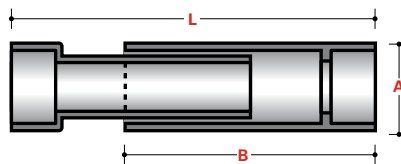

## SINGLE EXPANSION JOINT SOCKET X SOCKET WITH O-RING

	NOMINAL		XW ITEM NO ABOVE GROUND	A		B		L - MIN		L - MAX		WEIGHT	
	SIZE	TYPE									LBS	KG	
<input type="checkbox"/>	3/4"	XW	07C-XW-37	1.935"	(54)	12"	(305)	16.5"	(419)	24.5"	(622)	1.76	(0.80)
<input type="checkbox"/>	1"	XW	10C-XW-37	2.200"	(61)	12"	(305)	16.5"	(419)	24.5"	(622)	1.97	(0.89)
<input type="checkbox"/>	1-1/4"	XW	12C-XW-37	2.545"	(65)	12"	(305)	16.5"	(419)	24.5"	(622)	2.35	(1.07)
<input type="checkbox"/>	1-1/2"	XW	15C-XW-37	2.785"	(71)	12"	(305)	16.5"	(419)	24.5"	(622)	2.72	(1.23)
<input type="checkbox"/>	2"	XW	20D-XW-37	3.000"	(76)	12"	(305)	20.5"	(520)	28.5"	(724)	3.62	(1.64)
<input type="checkbox"/>	2-1/2"	XW	25D-XW-37	3.525"	(90)	12"	(305)	20.5"	(520)	28.5"	(724)	4.44	(2.01)
<input type="checkbox"/>	3"	XW	30D-XW-37	4.000"	(102)	12"	(305)	20.5"	(520)	28.5"	(724)	5.23	(2.37)
<input type="checkbox"/>	3-1/2"	XW	35D-XW-37	4.525"	(115)	12"	(305)	20.5"	(520)	28.5"	(724)	6.06	(2.75)
<input type="checkbox"/>	4"	XW	40D-XW-37	5.000"	(127)	14"	(356)	20.5"	(520)	28.5"	(724)	7.89	(3.58)
<input type="checkbox"/>	5"	XW	50D-XW-37	6.000"	(152)	14"	(356)	20.5"	(520)	28.5"	(724)	9.75	(4.43)
<input type="checkbox"/>	6"	XW	60D-XW-37	7.000"	(178)	14"	(356)	20.5"	(520)	28.5"	(724)	12.08	(5.48)
<input type="checkbox"/>	8"	XW	80C-XW-37	9.420"	(239)	14"	(356)	20.5"	(520)	28.5"	(724)	16.56	(7.52)

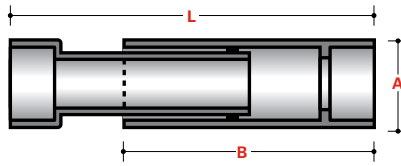

## DOUBLE EXPANSION JOINT, NO O-RINGS

	NOMINAL		XW ITEM NO ABOVE GROUND	A		B		L - MIN		L - MAX		WEIGHT	
	SIZE	TYPE									LBS	KG	
<input type="checkbox"/>	3/4"	XW	07C-XW-38	1.935"	(54)	17"	(432)	32"	(813)	48"	(1,219)	3.01	(1.37)
<input type="checkbox"/>	1"	XW	10C-XW-38	2.200"	(61)	17"	(432)	32"	(813)	48"	(1,219)	3.36	(1.53)
<input type="checkbox"/>	1-1/4"	XW	12C-XW-38	2.545"	(65)	17"	(432)	32"	(813)	48"	(1,219)	4.06	(1.84)
<input type="checkbox"/>	1-1/2"	XW	15C-XW-38	2.785"	(71)	17"	(432)	32"	(813)	48"	(1,219)	5.83	(2.65)
<input type="checkbox"/>	2"	XW	20D-XW-38	3.000"	(76)	17"	(432)	40"	(1,016)	56"	(1,422)	6.24	(2.83)
<input type="checkbox"/>	2-1/2"	XW	25D-XW-38	3.525"	(90)	17"	(432)	40"	(1,016)	56"	(1,422)	7.63	(3.46)
<input type="checkbox"/>	3"	XW	30D-XW-38	4.000"	(102)	17"	(432)	40"	(1,016)	56"	(1,422)	9.01	(4.09)
<input type="checkbox"/>	3-1/2"	XW	35D-XW-38	4.525"	(115)	17"	(432)	40"	(1,016)	56"	(1,422)	10.42	(4.72)
<input type="checkbox"/>	4"	XW	40D-XW-38	5.000"	(127)	17"	(432)	40"	(1,016)	56"	(1,422)	11.78	(5.35)
<input type="checkbox"/>	5"	XW	50D-XW-38	6.000"	(152)	17"	(432)	40"	(1,016)	56"	(1,422)	14.55	(6.61)
<input type="checkbox"/>	6"	XW	60D-XW-38	7.000"	(178)	17"	(432)	40"	(1,016)	56"	(1,422)	19.25	(8.74)
<input type="checkbox"/>	8"	XW	80C-XW-38	9.420"	(239)	17"	(432)	40"	(1,016)	56"	(1,422)	26.40	(11.99)

A double expansion joint is sometimes referred to as back-to-back expansion joint.

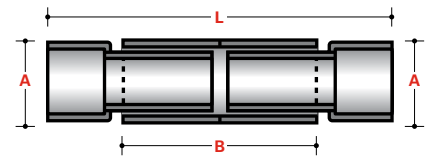

## DOUBLE EXPANSION JOINT WITH O-RINGS

	NOMINAL		XW ITEM NO ABOVE GROUND	A		B		L - MIN		L - MAX		WEIGHT	
	SIZE	TYPE									LBS	KG	
<input type="checkbox"/>	3/4"	XW	07C-XW-39	1.935"	(54)	17"	(432)	32"	(813)	48"	(1,219)	3.01	(1.37)
<input type="checkbox"/>	1"	XW	10C-XW-39	2.200"	(61)	17"	(432)	32"	(813)	48"	(1,219)	3.36	(1.53)
<input type="checkbox"/>	1-1/4"	XW	12C-XW-39	2.545"	(65)	17"	(432)	32"	(813)	48"	(1,219)	4.06	(1.84)
<input type="checkbox"/>	1-1/2"	XW	15C-XW-39	2.785"	(71)	17"	(432)	32"	(813)	48"	(1,219)	5.83	(2.65)
<input type="checkbox"/>	2"	XW	20D-XW-39	3.000"	(76)	17"	(432)	40"	(1,016)	56"	(1,422)	6.24	(2.83)
<input type="checkbox"/>	2-1/2"	XW	25D-XW-39	3.525"	(90)	17"	(432)	40"	(1,016)	56"	(1,422)	7.63	(3.46)
<input type="checkbox"/>	3"	XW	30D-XW-39	4.000"	(102)	17"	(432)	40"	(1,016)	56"	(1,422)	9.01	(4.09)
<input type="checkbox"/>	3-1/2"	XW	35D-XW-39	4.525"	(115)	17"	(432)	40"	(1,016)	56"	(1,422)	10.42	(4.72)
<input type="checkbox"/>	4"	XW	40D-XW-39	5.000"	(127)	17"	(432)	40"	(1,016)	56"	(1,422)	11.78	(5.35)
<input type="checkbox"/>	5"	XW	50D-XW-39	6.000"	(152)	17"	(432)	40"	(1,016)	56"	(1,422)	14.55	(6.61)
<input type="checkbox"/>	6"	XW	60D-XW-39	7.000"	(178)	17"	(432)	40"	(1,016)	56"	(1,422)	19.25	(8.74)
<input type="checkbox"/>	8"	XW	80C-XW-39	8.000"	(203)	17"	(432)	40"	(1,016)	56"	(1,422)	26.66	(11.63)

A double expansion joint is sometimes referred to as back-to-back expansion joint.

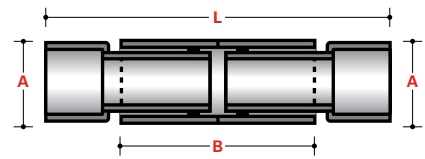

End of expansion joints subsection ▲

## ALIGNMENT / EXPANSION FITTING WITH O-RING

	NOMINAL		XW ITEM NO ABOVE GROUND	A		B		L - MIN		L - MAX		WEIGHT	
	SIZE	TYPE									LBS	KG	
<input type="checkbox"/>	3/4"	XW	07C-XW-31	1.935"	(54)	1.410"	(36)	40.5"	(1,028)	54.5"	(1,384)	4.27	(1.94)
<input type="checkbox"/>	1"	XW	10C-XW-31	2.200"	(61)	1.675"	(43)	40.5"	(1,028)	54.5"	(1,384)	4.76	(2.16)
<input type="checkbox"/>	1-1/4"	XW	12C-XW-31	2.545"	(65)	2.020"	(51)	40.5"	(1,028)	54.5"	(1,384)	5.74	(2.60)
<input type="checkbox"/>	1-1/2"	XW	15C-XW-31	2.785"	(71)	2.260"	(57)	40.5"	(1,028)	54.5"	(1,384)	8.26	(3.75)
<input type="checkbox"/>	2"	XW	20D-XW-31	3.000"	(76)	2.500"	(64)	42.5"	(1,080)	56.5"	(1,435)	8.82	(4.00)
<input type="checkbox"/>	2-1/2"	XW	25D-XW-31	3.525"	(90)	3.000"	(76)	42.5"	(1,080)	56.5"	(1,435)	10.78	(4.89)
<input type="checkbox"/>	3"	XW	30D-XW-31	4.000"	(102)	3.500"	(89)	42.5"	(1,080)	56.5"	(1,435)	12.74	(5.78)
<input type="checkbox"/>	3-1/2"	XW	35D-XW-31	4.525"	(115)	4.000"	(102)	42.5"	(1,080)	56.5"	(1,435)	14.70	(6.67)
<input type="checkbox"/>	4"	XW	40D-XW-31	5.000"	(127)	4.500"	(114)	42.5"	(1,080)	56.5"	(1,435)	16.66	(7.56)
<input type="checkbox"/>	5"	XW	50D-XW-31	6.000"	(152)	5.500"	(140)	42.5"	(1,080)	56.5"	(1,435)	20.58	(9.34)
<input type="checkbox"/>	6"	XW	60D-XW-31	7.000"	(178)	6.500"	(165)	42.5"	(1,080)	56.5"	(1,435)	24.50	(11.12)
<input type="checkbox"/>	8"	XW	80C-XW-31	8.000"	(203)	7.500"	(191)	42.5"	(1,080)	56.5"	(1,435)	29.16	(13.23)

Alignment/Expansion fitting is sometimes referred to as an Expansion/Deflection joint.

(The clamps holding the rubber sleeve connecting the two nipples are made from stainless steel for corrosion protection.)

Note: All Expansion Joints have a yellow line on the nipple end of the joint for proper installation.

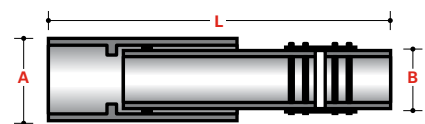



## END BELLS – SOCKET TYPE

	NOMINAL		XW ITEM NO		D1	D2	L	M	B	WEIGHT	
	SIZE	TYPE	BELOW GROUND	ABOVE GROUND						LBS	KG
<input type="checkbox"/>	3/4"	XW	07A-XW-29	07C-XW-29	1.43" (36)	1.94" (54)	1.60" (45)	2.48" (63)	0.31" (8)	0.63	(0.28)
<input type="checkbox"/>	1"	XW	10A-XW-29	10C-XW-29	1.70" (43)	2.20" (61)	1.60" (45)	2.70" (68)	0.31" (8)	0.70	(0.32)
<input type="checkbox"/>	1-1/4"	XW	12A-XW-29	12C-XW-29	2.05" (52)	2.55" (65)	1.60" (45)	3.11" (79)	0.31" (8)	0.85	(0.38)
<input type="checkbox"/>	1-1/2"	XW	15A-XW-29	15C-XW-29	2.29" (58)	2.79" (71)	1.60" (45)	3.35" (85)	0.31" (8)	1.22	(0.55)
<input type="checkbox"/>	2"	XW	20B-XW-29	20D-XW-29	2.52" (64)	3.02" (76)	3.00" (76)	3.62" (92)	0.31" (8)	1.30	(0.59)
<input type="checkbox"/>	2-1/2"	XW	25B-XW-29	25D-XW-29	3.02" (77)	3.53" (90)	3.00" (76)	4.22" (107)	0.31" (8)	1.59	(0.72)
<input type="checkbox"/>	3"	XW	30B-XW-29	30D-XW-29	3.52" (89)	4.02" (102)	3.00" (76)	4.62" (117)	0.31" (8)	1.90	(0.86)
<input type="checkbox"/>	3-1/2"	XW	35B-XW-29	35D-XW-29	4.03" (102)	4.53" (115)	3.00" (76)	5.48" (139)	0.31" (8)	2.17	(0.98)
<input type="checkbox"/>	4"	XW	40B-XW-29	40D-XW-29	4.52" (115)	5.02" (128)	5.00" (127)	5.62" (143)	0.31" (8)	2.40	(1.09)
<input type="checkbox"/>	5"	XW	50B-XW-29	50D-XW-29	5.52" (140)	6.02" (153)	5.00" (127)	6.62" (168)	0.31" (8)	2.42	(1.10)
<input type="checkbox"/>	6"	XW	60B-XW-29	60D-XW-29	6.52" (166)	7.02" (178)	5.00" (127)	7.62" (194)	0.31" (8)	2.50	(1.13)
<input type="checkbox"/>	8"	XW	80A-XW-29	80C-XW-29	8.48" (215)	9.00" (229)	5.00" (127)	9.40" (239)	0.31" (8)	-	-

End bells are used for creating a permanent termination into a box and have a smooth surface that the cable can be pulled over.

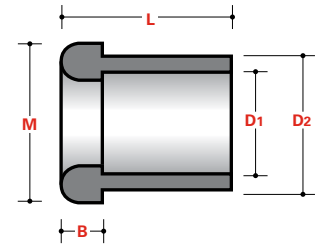

## FIBERGLASS END CAPS WITH GASKET

	NOMINAL		XW ITEM NO		D	L	WEIGHT	
	SIZE	TYPE	BELOW GROUND	ABOVE GROUND			LBS	KG
<input type="checkbox"/>	3/4"	XW	07A-XW-23-G	07C-XW-23-G	1.43" (36)	4" (102)	0.31	(0.15)
<input type="checkbox"/>	1"	XW	10A-XW-23-G	10C-XW-23-G	1.70" (43)	4" (102)	0.46	(0.21)
<input type="checkbox"/>	1-1/4"	XW	12A-XW-23-G	12C-XW-23-G	2.04" (52)	4" (102)	0.53	(0.24)
<input type="checkbox"/>	1-1/2"	XW	15A-XW-23-G	15C-XW-23-G	2.28" (58)	4" (102)	0.65	(0.29)
<input type="checkbox"/>	2"	XW	20B-XW-23-G	20D-XW-23-G	2.52" (64)	4" (102)	0.70	(0.32)
<input type="checkbox"/>	2-1/2"	XW	25B-XW-23-G	25D-XW-23-G	3.02" (76)	4" (102)	0.85	(0.39)
<input type="checkbox"/>	3"	XW	30B-XW-23-G	30D-XW-23-G	3.52" (89)	4" (102)	0.95	(0.43)
<input type="checkbox"/>	3-1/2"	XW	35B-XW-23-G	35D-XW-23-G	4.02" (102)	4" (102)	1.20	(0.54)
<input type="checkbox"/>	4"	XW	40B-XW-23-G	40D-XW-23-G	4.52" (115)	4" (102)	1.40	(0.64)
<input type="checkbox"/>	5"	XW	50B-XW-23-G	50D-XW-23-G	5.52" (140)	4" (102)	1.90	(0.86)
<input type="checkbox"/>	6"	XW	60B-XW-23-G	60D-XW-23-G	6.52" (165)	4" (102)	2.40	(1.09)

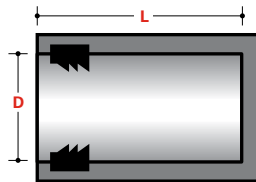

## SPLIT ANCHOR RINGS

	NOMINAL		XW ITEM NO		F		L		WEIGHT	
	SIZE	TYPE	BELOW GROUND	ABOVE GROUND					LBS	KG
<input type="checkbox"/>	3/4"	XW	07A-XW-28	07C-XW-28	0.25"	(6)	3"	(76)	0.25	(0.11)
<input type="checkbox"/>	1"	XW	10A-XW-28	10C-XW-28	0.25"	(6)	3"	(76)	0.28	(0.13)
<input type="checkbox"/>	1-1/4"	XW	12A-XW-28	12C-XW-28	0.25"	(6)	3"	(76)	0.34	(0.15)
<input type="checkbox"/>	1-1/2"	XW	15A-XW-28	15C-XW-28	0.25"	(6)	3"	(76)	0.49	(0.22)
<input type="checkbox"/>	2"	XW	20B-XW-28	20D-XW-28	0.25"	(6)	3"	(76)	0.52	(0.24)
<input type="checkbox"/>	2-1/2"	XW	25B-XW-28	25D-XW-28	0.25"	(6)	3"	(76)	0.64	(0.29)
<input type="checkbox"/>	3"	XW	30B-XW-28	30D-XW-28	0.25"	(6)	3"	(76)	0.80	(0.36)
<input type="checkbox"/>	3-1/2"	XW	35B-XW-28	35D-XW-28	0.25"	(6)	3"	(76)	0.87	(0.39)
<input type="checkbox"/>	4"	XW	40B-XW-28	40D-XW-28	0.25"	(6)	3"	(76)	0.98	(0.44)
<input type="checkbox"/>	5"	XW	50B-XW-28	50D-XW-28	0.25"	(6)	3"	(76)	1.15	(0.52)
<input type="checkbox"/>	6"	XW	60B-XW-28	60D-XW-28	0.25"	(6)	3"	(76)	1.25	(0.57)

Split anchor rings are always supplied in pairs and are used for above ground installations in order to create fixed points. The split anchor rings are placed around the hanger closest to the mid point between two expansion joints. One pair of split anchor rings is placed on each side of the hanger. The split anchor rings are bonded with epoxy adhesive to the outside of the conduit. The hanger where split anchor rings are used is called an anchor hanger and is normally braced, see Bridge Hanger section in this catalog.

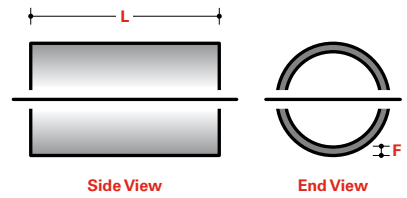

For further information, use your smart phone's QR code scanner to learn more about **Champion Fiberglass split anchor rings**.

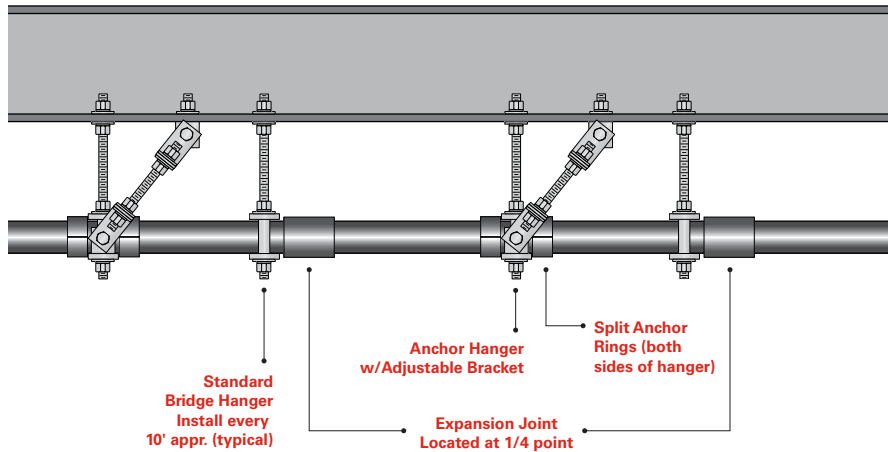

**SLIP COLLARS**

	SIZE	XW ITEM NO	ID	OD	WALL THICKNESS		L	IPS STD SIZE	CHAMPION SLIP COLLAR TO CONDUIT DIAMETRICAL SLIP GAP	
								OD		
<input type="checkbox"/>	3/4"	07C-XW-41	1.410" (36)	1.535" (39)	0.1825" (5)	3" (76)	1.900" (48)	0.125" (3.18)		
<input type="checkbox"/>	1"	10C-XW-41	1.675" (43)	1.800" (41)	0.2875" (7)	3" (76)	2.375" (60)	0.125" (3.18)		
<input type="checkbox"/>	1-1/4"	12C-XW-41	2.020" (51)	2.145" (54)	0.365" (9)	3" (76)	2.875" (73)	0.125" (3.18)		
<input type="checkbox"/>	1-1/2"	15C-XW-41	2.260" (57)	2.385" (61)	0.245" (6)	3" (76)	2.875" (73)	0.125" (3.18)		
<input type="checkbox"/>	2"	20D-XW-41	2.500" (64)	2.625" (67)	0.4125" (10)	3" (76)	3.450" (88)	0.125" (3.18)		
<input type="checkbox"/>	2-1/2"	25D-XW-41	3.000" (76)	3.125" (79)	0.1625" (4)	3" (76)	3.450" (88)	0.125" (3.18)		
<input type="checkbox"/>	3"	30D-XW-41	3.500" (89)	3.625" (92)	0.1875" (5)	3" (76)	4.000" (102)	0.125" (3.18)		
<input type="checkbox"/>	3-1/2"	35D-XW-41	4.000" (102)	4.125" (105)	0.1875" (5)	3" (76)	4.500" (114)	0.125" (3.18)		
<input type="checkbox"/>	4"	40D-XW-41	4.500" (114)	4.625" (117)	0.469" (12)	3" (76)	5.563" (141)	0.125" (3.18)		
<input type="checkbox"/>	5"	50D-XW-41	5.500" (140)	5.625" (143)	0.500" (13)	3" (76)	6.625" (168)	0.125" (3.18)		
<input type="checkbox"/>	6"	60D-XW-41	6.500" (165)	6.625" (168)	1.000" (25)	3" (76)	8.625" (219)	0.125" (3.18)		

Champion Fiberglass Slip Collars allow unrestricted expansion/contraction movement of RTRC conduit while still providing proper support to the conduit system. The Slip Collars eliminate the expansion/contraction binding that naturally occurs in traditional pipe clamp installations.

The advantages of Champion Fiberglass Slip Collars include:

- Can be used with steel or fiberglass pipe clamps.
- Available in black or grey epoxy.
- Heavy-duty wall thickness collar allows for considerable pipe clamp tightening without any force transfer to conduit.

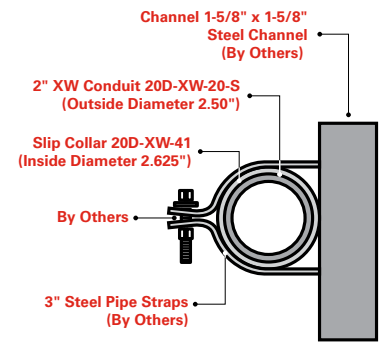

End View

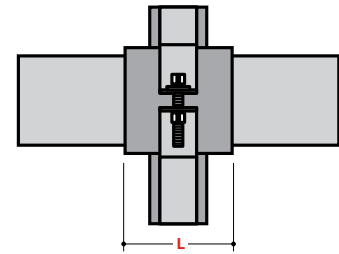

Plan View