

Installation Instructions

These instructions are intended to provide assistance only as a guide to obtain the most appropriate and satisfactory installation of Champion Fiberglass conduit systems.

These instructions are not intended to replace the responsibilities of engineers, customer representatives, owners or other persons responsible in establishing engineering design practices and procedures that are best suited for individual job site conditions.

Epoxy Conduit

Champion Fiberglass conduit maintains the following standards and listing compliances:

- UL 2420 (Below Ground)
- UL 2515 (Above Ground)
- Class I, Division 2 (XW)
- ISO 9001
- ISO 14001
- NEC (Article 355 - RTRC Conduit - Reinforced Thermoset Resin Conduit)
- CSA (Section 12-0200 thru 12-1220 Rigid RTRC Conduit CSA)

Notes:

- All conduit sections are provided with belled ends.
- No couplings are required for straight sections.
- Standard conduit lengths are 10 and 20 ft.
- Standard conduit colors are black and grey with special colors available upon request.
- Standard and long radius elbows are available as well as elbows with special radii upon request.
- Conduit bodies with threaded hubs are available upon request.

Scope

These instructions cover recommendations for above/below ground installation procedures, Class I, Division 2 installation procedures, joining of conduit sections, repair of damaged conduit section (with and without installed cable), shipping, handling and storage of Champion Fiberglass epoxy RTRC conduit systems.

Concrete Encasement and Direct Burial

The following conduits are approved for concrete encasement and direct burial systems:

1. Standard Wall (SW - .070" wall) 3/4" thru 4" diameters
2. Medium Wall (MW - .096" wall) 5" thru 6" diameters
3. Heavy Wall (HW - .096" wall) 4" diameter
4. Heavy Wall (HW - .110" wall) 5" thru 6" diameters
5. Heavy Wall (HW - .125" wall) 8" diameter
6. Heavy Wall (HW - .188" wall) 10" thru 12" diameters
7. Extra Heavy Wall (XW - .250" wall) 3/4" thru 12" diameters

Conduit Spacers

There are many different configurations of commercially available spacers.

- **Encased Burial** conduit separation can be achieved by the use of commercially available spacers. An adequately designed spacer will have more flow area and sacrificial grout pipe holes.
- **Direct Burial** conduit separation spacers must meet the specifications of the design engineer. The spacers must be designed for such use and appropriate backfill material and its compaction must be specified as well. Proper design engineering must be applied for the use of direct burial spacers otherwise excessive conduit point load deflections may result.
- **Spacing Considerations:** Stock spacers provide 1-1/2", 2" and 3" conduit separations.

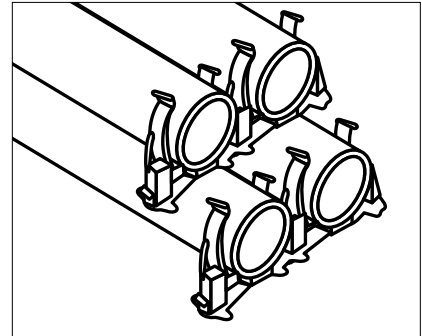
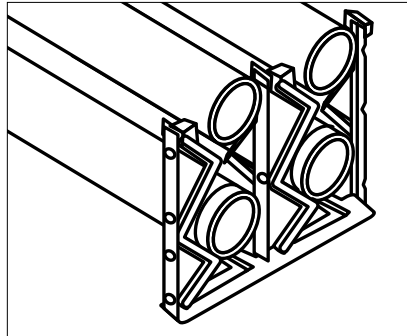
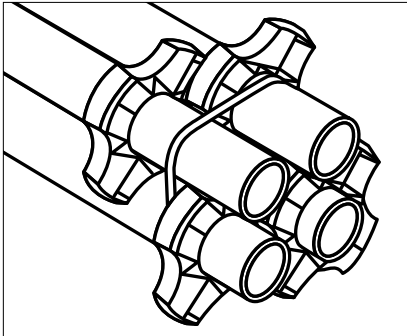

Underground Installation

Proper Installation

- **Conduit** is properly installed if the inside diameter of each duct is adequate to allow the passage of the specified deflection mandrel.
- **To limit deflection**, special attention should be paid to trench bedding, duct separation, spacer interval, type of backfill material and amount of compaction.

Trench Excavation

- All federal, state and local regulations should be followed.
- Routing of the underground conduit should be coordinated with all utility companies.
- The **trench dimensions** should be determined
 - The trench depth is determined by the height of the duct bank plus the minimum required cover over the duct bank.
 - The trench width is determined by the duct bank width plus a three-inch space on each side to accommodate the backfill and/or shoring materials.
- Trench Wall
 - Unstable soil conditions should be stabilized before laying the duct. Well points or under drains may be required to control excessive groundwater conditions.
 - Soil conditions may require shoring. Duct should not be disturbed by removal of shoring materials.
- Trench Bottom
 - The trench bottom should be smooth and free of any debris that may impede the spacer positioning.
 - Rocky bottom trenches may require a layer of compactable bedding material.
 - For direct burial applications, bedding must be uniformly graded for continuous duct support.
 - Blocking or mounding should not be used to raise the duct to grade.
 - Unstable trench bottoms may require crushed stone or gravel bedding to provide duct stability.
 - The maximum bedding particle size should be one inch.

Trenchless (Steel Casing) Applications

The trenchless application grouting process is very technical; it should only be undertaken by a grouting contractor who completely understands and has considered all aspects of the process. Special attention should be given to the following applications:

- Jack and Bore
- Microtunnel/Tunneling
- Horizontal Directional Drilled Bores (HDD)
- Auger Bore

The grouting contractor must fully understand and take special consideration of:

- The buckling pressures of the RTRC conduit when pumping or pouring grout.
- The use of conduit spacers and their grout flow capabilities inside the casing.
(A properly designed spacer will have more flow area and sacrificial grout pipe holes.)
- A congested bore will restrict grout flow and may require higher grouting pressures or a more fluid grout than will an open, less congested bore.
- Inclined Jack and Bores are exposed to increased hydrostatic head pressure and dynamic pumping pressures.
- Grouting is best performed from the high side of a Jack and Bore, utilizing the longest sacrificial grout pipe and working upward with subsequently shorter pipes. (In level short bores, an experienced grout specialist may use a single mid-span grout pipe.)
- The proper use of concrete admixtures can significantly improve the performance of all cementitious grouts.
- Grout line pressure must be monitored at the point of injection. The pressure gauges on the concrete pump are not sufficient – the pump operator must be aware of grout line pressure at all times. Back pressure, not line pressure, is what contributes to conduit damage.
- In trenchless applications, grout is pumped into a sealed environment. Vents should always be installed at both ends, regardless of bore pitch. They should be sized at the same or larger diameter than the largest injection pipe.
- As a general rule, all RTRC conduits should be filled with water prior to pumping and pressurized where grouting pressures could potentially damage the conduit.
- All conduit bundles should be pushed into the steel casing as this applies the least amount of stress to the conduit adhesive joint connections.
- In trenchless grouting, maximum pressure occurs during the grouting operation, yet maximum temperature from heat of hydration occurs hours later.
- A properly designed and executed grout plan should be established prior to any grouting. Having a qualified trenchless grouting specialist assist on even the smallest projects can prevent major headaches.
- Any grout (cellular, flowfill, thermal, etc.) should be designed by someone experienced in trenchless applications. Most calls to ready-mix companies for a pumpable grout will not result in the delivery of the correct mix.
- **Remember:** A pumpable grout does not need to be flowable; a flowable grout may not be pumpable. **Trenchless grouting applications require both.**

If you have concerns or need additional information regarding this specialized grouting installation process, please contact Champion Fiberglass directly.

Note: This information is to be used only as a guideline. Champion Fiberglass is not a grouting contractor, nor does it represent itself as such. Please contact a qualified grouting specialist for detailed project specifics.



Field Cutting

To make conduit field cuts, the tools required are a fine tooth handheld hack saw, porta-band saw or a chop saw with a diamond cutting blade. Marking the fiberglass conduit for cutting will require a contrasting colored marker. Remove any cutting burrs or ridges with 60-grit emery cloth.

Proper field cutting PPE to include:

- Long sleeve clothing
- Gloves
- Safety glasses
- Particulate respirator (3M N95 or equivalent)



For further information, use your smart phone's camera or QR code viewer to view the **Champion Field Cutting Video**.



Bonding/Adhesive Joint Connections

The adhesive connections between conduit sections, elbows and conduit bodies are made with Champion's two-part epoxy adhesives (Champion Mix®). Care should be taken to choose the correct adhesive for the job site ambient temperature when the adhesive will be used. There are three adhesive tube sizes and temperature ranges and curing rates to choose from.

ITEM NO	SIZE	TEMPERATURE RANGE	APPROXIMATE CURING TIME
CM-570	50 ML	70°F (21°C) and above	30–45 minutes
CM-570-FG	50 ML	70°F (21°C) and above	20–30 minutes
CM-570-SFG	50 ML	70°F (21°C) and above	3–7 minutes
CM-540	50 ML	40°–70°F (4°C–21°C)	30–45 minutes
CM-540-FG	50 ML	40°–70°F (4°C–21°C)	20–30 minutes
CM-540-SFG	50 ML	40°–70°F (4°C–21°C)	3–7 minutes
CM-1070	80 ML	70°F (21°C) and above	30–45 minutes
CM-1070-FG	80 ML	70°F (21°C) and above	20–30 minutes
CM-1070-SFG	80 ML	70°F (21°C) and above	3–7 minutes
CM-1040	80 ML	40°–70°F (4°C–21°C)	30–45 minutes
CM-1040-FG	80 ML	40°–70°F (4°C–21°C)	20–30 minutes
CM-1040-SFG	80 ML	40°–70°F (4°C–21°C)	3–7 minutes
CM-2070	300 ML	70°F (21°C) and above	30–45 minutes
CM-2070-FG	300 ML	70°F (21°C) and above	20–30 minutes
CM-2070-SFG	300 ML	70°F (21°C) and above	3–7 minutes
CM-2040	300 ML	40°–70°F (4°C–21°C)	30–45 minutes
CM-2040-FG	300 ML	40°–70°F (4°C–21°C)	20–30 minutes
CM-2040-SFG	300 ML	40°–70°F (4°C–21°C)	3–7 minutes

Once the correct adhesive is chosen, the parts can be prepared for bonding. This is achieved by sanding the areas to be bonded with 60-grit emery cloth. The surfaces to be bonded should be sanded until the factory finish (sheen) is removed. These surfaces would include field-cut conduit ends, sleeve and expansion couplings (interior) and fitting hubs (interior). Sanding is easily accomplished with minimal time and effort. All factory conduit and plain elbow ends come pre-sanded.



Apply the Champion Mix® two-part epoxy adhesive to the conduit ends. NEVER apply adhesive to the inside of sleeve couplings or fitting sleeves as this could potentially cause the adhesive to drip inside the conduit/fittings and possibly interfere with the cable pulling process. Champion Mix is designed to permanently bond fittings and the joints of fiberglass reinforced epoxy conduit. It is also designed for use with pultruded polyester and vinyl ester fiberglass components.



For further information, use your smart phone's camera or QR code scanner to view the **Champion Bonding Epoxy Conduit Video**.

Champion Mix - Two-part Epoxy Adhesive Cartridges

Estimated Number of Joints Per Container

(estimated only - varies depending on amount of adhesive applied per application)

50 ML		150 ML		300 ML	
SIZE	JOINTS PER CONTAINER	SIZE	JOINTS PER CONTAINER	SIZE	JOINTS PER CONTAINER
3/4"	16	3/4"	50	3/4"	100
1"	14	1"	43	1"	85
1-1/4"	12	1-1/4"	37	1-1/4"	75
1-1/2"	10	1-1/2"	30	1-1/2"	60
2"	8	2"	25	2"	50
2-1/2"	6	2-1/2"	20	2-1/2"	40
3"	5	3"	17	3"	35
3-1/2"	5	3-1/2"	15	3-1/2"	30
4"	4	4"	12	4"	25
5"	3	5"	10	5"	20
6"	2	6"	7	6"	15

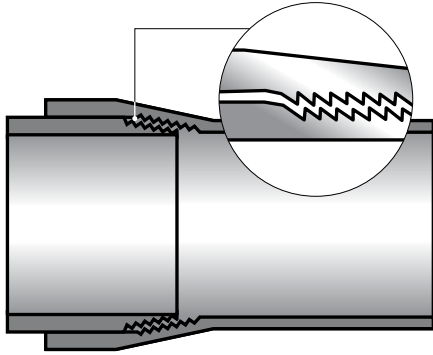

For further information, use your smart phone's camera or QR code scanner to learn more about **Champion's Epoxy Adhesive Calculator**.

Assembly**Conduit Joining Systems****Interference Joint**

The Interference Joint connection can be used for below ground concrete encasement applications.

Some features of the Interference Joint connection are:

- Consists of bell and spigot.
- For easy installation, spigot end features buttress-type male threads; belled end features female mating threads.
- Tapered threads make for quick, easy connection when properly seated.
- High pull-out strength of 1,000 lbs without adhesive.
- Concrete tight joint - not water tight.
- The Interference Joint connection is provided with the following conduits:
 - IPS conduits 2" through 8" diameters
 - ID conduits 2" through 6" diameters
- The Interference Joint connection will provide a concrete tight connection without the use of epoxy adhesive.
- The Interference Joint connection can be used for above ground applications when conduit sections are connected with epoxy adhesive (Tight Lock Joint).

To learn more about how to assemble the Interference Joint connection, please see the installation video on our website.

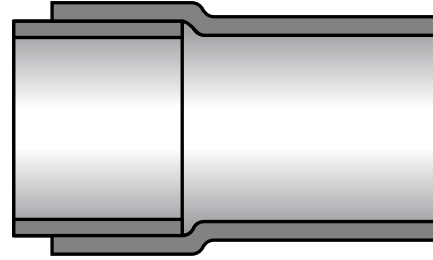
**Straight Socket Joint**

The Straight Socket Joint connection can be used for above and below ground applications.

Some features of the Straight Socket Joint connection are:

- Consists of bell and spigot.
- Spigot easily slides into belled end.
- Intended for use with Champion Mix® epoxy adhesive.
- High pull-out strength.
- Concrete tight and water-tight joint.
- Straight Socket joining system is provided with the following conduits:
 - IPS conduits 3/4" through 1-1/2" diameters*
 - ID conduits 8" through 12" diameters**
 - XW conduits - all diameters

To learn more about how to assemble the Straight Socket Joint connection, please see the installation video on our website.

* Straight Socket Joint connection is available for sizes 2" through 8" upon request, otherwise interference straight joint provided when available.

** Straight Socket Joint connection is available for sizes 2" through 6" upon request, otherwise interference joint provided when available.

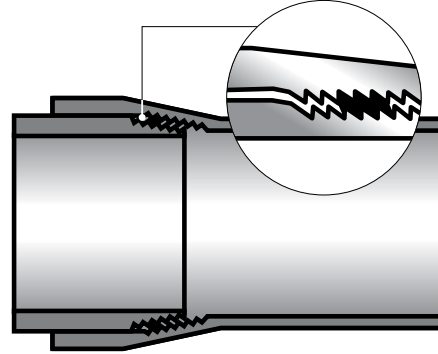
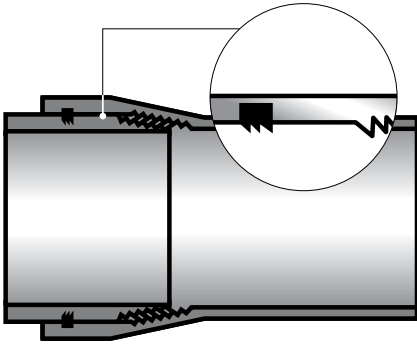

Gasket Joint (Triple Seal)

The Gasket Joint connection can be used with direct burial or concrete embedment underground applications.

Some features of the Gasket Joint connection are:

- Consists of bell and spigot.
- Belled end has Triple Seal gasket with Interference Joint.
- Gasket seats into permanent groove wound into the conduit.
- Concrete tight and water-tight joint.
- High pull-out strength of 2,000 lbs.
- Pull-out strength of 500 lbs without threads.
- The Gasket Joint connection is provided with the following conduits:
 - IPS conduits 3/4" through 8" diameters
 - ID conduits 2" through 6" diameters

To learn more about how to assemble the Gasket Joint connection, please see the installation video on our website.

Tight Lock Joint

The Tight Lock Joint connection is a permanent Interference Joint connection that utilizes the Champion Mix® epoxy adhesive. This connection can be used for above or below ground applications.

- The adhesive is applied to the spigot end of the conduit and inserted into the belled conduit end. Once cured, the adhesive joint has a tensile strength that surpasses the conduit glass substrate.
- The Tight Lock Joint connection provides a water-tight connection that can be used in above and below ground applications.
- The Tight Lock Joint connection is only available in IPS and ID conduits sizes 2" and above on SW, MW and HW epoxy resin conduits.
- The Tight Lock Joint connection is available exclusively from Champion Fiberglass.

To learn more about how to assemble the Tight Lock Joint connection, please see the installation video on our website.



For further information, use your smart phone's camera or QR code scanner to view the **Champion Interference and Gasket Joint Assembly Video**.

Expansion Joints

Expansion joints are available in a wide selection of styles and total movement lengths. Special length movement expansion joints are available upon request. The expansion and contraction of epoxy conduit is usually larger and independent of any expansion and contraction of the structure or bridge.

Expansion Joint Spacing Requirements:

- Conduit runs less than 50 ft - no expansion joint required
- 50-200 ft conduit runs - one joint required in the center of the run
- Conduit runs over 200 ft - one joint required every 200 ft
- Expansion joints should be installed at the 1/4 point of the span whenever possible.

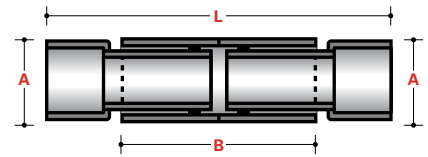

TEMP CHANGE °F	CONDUIT LENGTH CHANGE (INCHES PER/100 FT)	TEMP CHANGE °F	CONDUIT LENGTH CHANGE (INCHES PER/100 FT)
5°	.09"	60°	1.08"
10°	.18"	80°	1.44"
20°	.36"	100°	1.80"
40°	.72"	120°	2.16"

Conduit Bodies

Champion Fiberglass conduit bodies are available in LBs, Cs, LLs, LRs, Ts, TBs and Xs. They are compression molded from vinyl ester resin and are supplied with stainless steel cover set screws and a high-performance silicon gasket which provides a water-tight, corrosion-resistant seal between the cover and conduit body. Each conduit body will be supplied with Champion's unique "Champ-Seal" gasketing system. This is a silicon-based, water-tight and corrosion-resistant gasketing system that completely resists impression setting. Conduit bodies can also be provided with threaded hub inserts upon request. Conduit bodies are connected to conduit straight lengths with Champion Mix two-part epoxy adhesive.

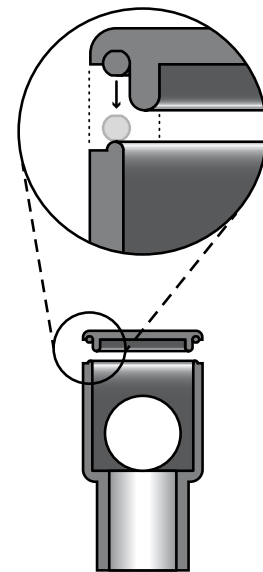

Class I, Division 2 (Zone 2)

Champion Fiberglass Haz Duct® XW conduit (XW - .250" wall thickness) can be used in Class I, Division 2 hazardous areas as illustrated below:

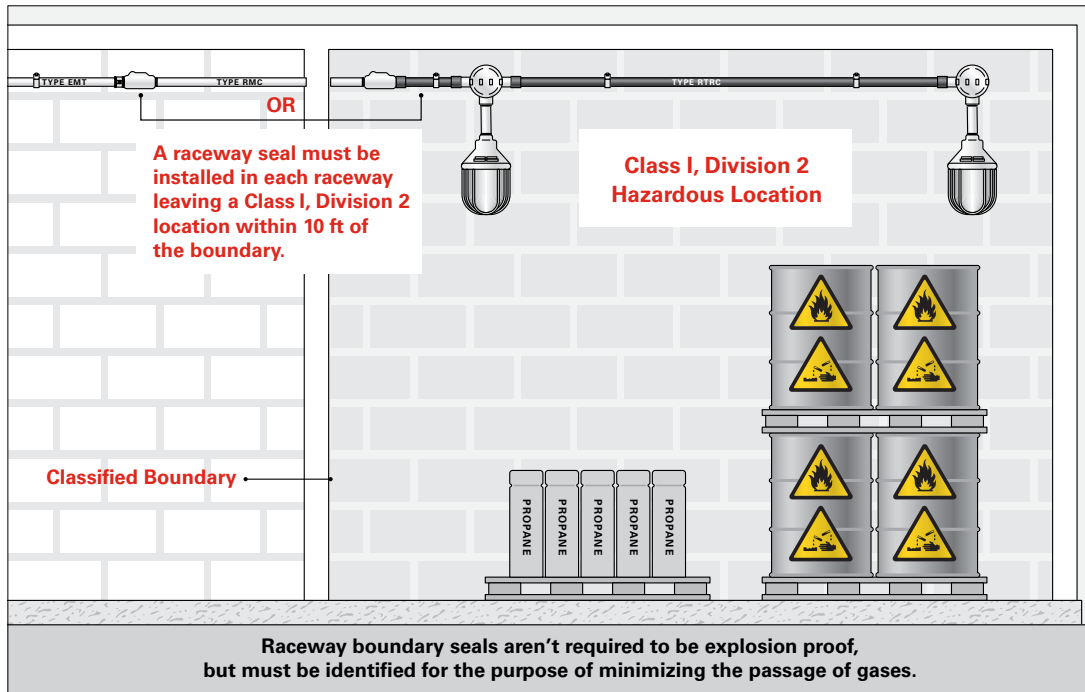
**Field Bending**

In order to field bend Champion Fiberglass Conduit, you will need a PVC hot-box and a one shot hydraulic conduit bender. Care should be taken to choose the correct sized PVC hot-box based on the outside diameter of the conduit and length of the bend. Begin the bending process by heating the conduit to be bent in the PVC hot-box to 240°F (116°C). The conduit should be rolled while being heated and the temperature should be periodically checked with a digital thermometer until it reaches 240°F (116°C). Once the conduit reaches 240°F, place it into the bender and bend it to the desired radius (consult factory for RTRC minimum bending radii).

Once the elbow is bent, it is recommended to let it cool while still in the bender. The cooling process can be shortened by using a cool wet rag or running cool water over the bent elbow prior to removing it from the bender.

Field bending is governed by **Article 355** in the **National Electric Code**. Bends shall be made so that the conduit will not be damaged and the internal diameter of the conduit will not be effectively reduced. Field bends shall be made only with bending equipment identified for that purpose. The radius of the curve to the centerline of such bends shall not be less than shown in the **NEC Article 355**.

Check the Champion Fiberglass catalog elbows section to verify the specific bending radius selected. Generally, it is difficult to field bend a tighter radius than what can be done at the factory.

The process for field bending is relatively simple. The conduit is heated in a standard PVC hot-box, and then bent with bending equipment identified for this purpose.

National Electric Code (NEC): Radius of Conduit and Tubing Bends

SIZE OF CONDUIT		OTHER BENDS	
TRADE SIZE	METRIC DESIGNATOR	IN	MM
3/4"	21	5"	127.0
1"	27	6"	152.4
1-1/4"	35	8"	203.2
1-1/2"	41	10"	254.0
2"	53	12"	304.8
2-1/2"	63	15"	381.0
3"	78	18"	457.2
3-1/2"	91	21"	533.4
4"	103	24"	609.6
5"	129	30"	762.0
6"	155	36"	914.4

For the standard wall sizes listed below, the heating time ranges from approximately 20 seconds to 65 seconds depending on the temperature of the hot-box and the size of the conduit. After heating, immediately place conduit in the bending equipment and begin to bend. It is extremely important that the proper bending equipment is used. Allow the bend to cool at the desired angle.

CONDUIT SIZE (IN)		APPROX HEATING TIME TO BEND (SEC)
3/4"	IPS	25-30
1"	IPS	30-35
1-1/4"	IPS	30-35
1-1/2"	IPS	35-40
2"	IPS	40-60
2-1/2"	IPS	45-65

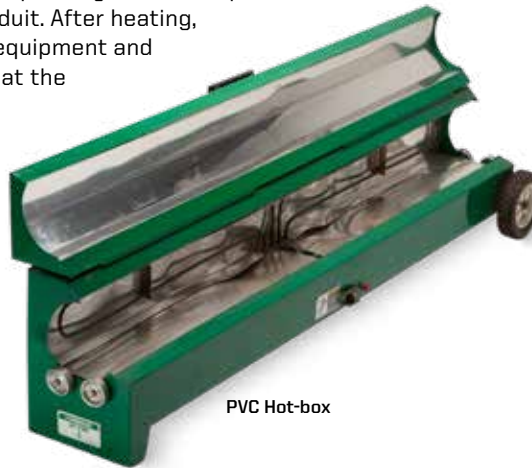

PVC Hot-box

When installing field bent fiberglass conduit, the elbow or offset should immediately be installed and supported by conduit straps on both ends of the elbow and offset.



For further information, use your smart phone's camera or QR code scanner to view the **Champion Fiberglass Bending Epoxy Conduit Video**.

Bridge Hangers

Champion's bridge hanger installation video details where to install the hangers (spacing) and shows how to locate the conduit expansion joints, split ring anchors and anchor hangers.



For further information, use your smart phone's camera or QR code scanner to view the **Champion Fiberglass Bridge Hanger Video**.

Handling and Storage

Transportation

Conduit is shipped in self-supporting crates designed to be unloaded by forklift. Crates should not be dropped from the truck trailer flatbeds. Conduit may also be shipped via enclosed vans in bundles. Care should be taken to avoid prolonged storage in enclosed vans as excessive stacking weight and elevated temperatures may cause the bottom rows of conduits to become oval in shape. Elbows are shipped with banding which should not be removed until the elbows are ready to be installed. Elbows should be stored in a cool, shaded area if possible.

Packaging Information for Conduit

NOMINAL SIZE	IPS (IRON PIPE SIZE)			ID (TUBULAR SIZE)		
	TRUCKLOAD QUANTITIES (FT)	CRATE QUANTITIES (FT)	APPROX CRATE DIMENSIONS (FT)	TRUCKLOAD QUANTITIES (FT)	CRATE QUANTITIES (FT)	APPROX CRATE DIMENSIONS (FT)
3/4"	*	3,600'	3' x 2' x 10'			
1"	*	2,400'	2.7' x 2' x 10'			
1-1/4"	*	3,840'	4' x 1.5' x 20'			
1-1/2"	*	3,680'	4' x 1.8' x 20'			
2"	*	2,480'	4' x 2' x 20'	*	3,000'	4' x 2' x 20'
3"	25,760'	3,220'	4' x 4' x 20'	34,560'	4,320'	4' x 4' x 20'
3-1/2"	-			25,760'	3,220'	4' x 4' x 20'
4"	15,040'	1,880'	4' x 4' x 20'	18,240'	2,280'	4' x 4' x 20'
5"	10,880'	1,360'	4' x 4' x 20'	12,000'	1,500'	4' x 4' x 20'
6"	7,040'	880'	4' x 4' x 20'	8,320'	1,040'	4' x 4' x 20'

* Contact Champion Fiberglass directly for information and XW conduit packaging.

Storage

- **Conduit** crates should be stored on a level surface. The wooden frames should line up so the load will be transferred to the wood frames rather than the conduit. The height of stacked conduit should be limited to twelve feet.
- **Elbows and accessories**, when stored outdoors, should be under cover to protect items in cartons from the outdoor elements. Elbows are shipped with banding which should not be removed until the elbows are ready to be installed. Elbows should be stored in a cool, shaded area if possible.
- **Epoxy adhesives** should be stored at room temperature except when in use on the job site. Adhesives should not be stored in freezing areas as this will cause handling problems during the application process.

